

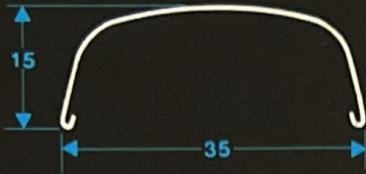

3R 35

NEW



T 36

NEW

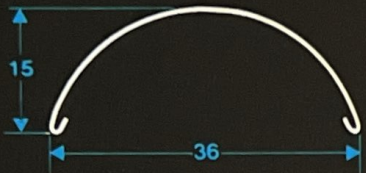

3R 38

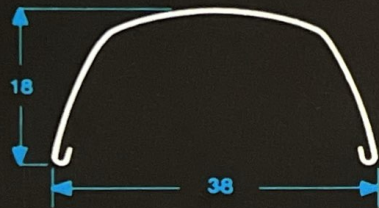

C 38

NEW

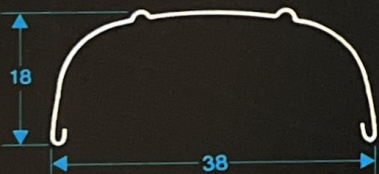

61 S

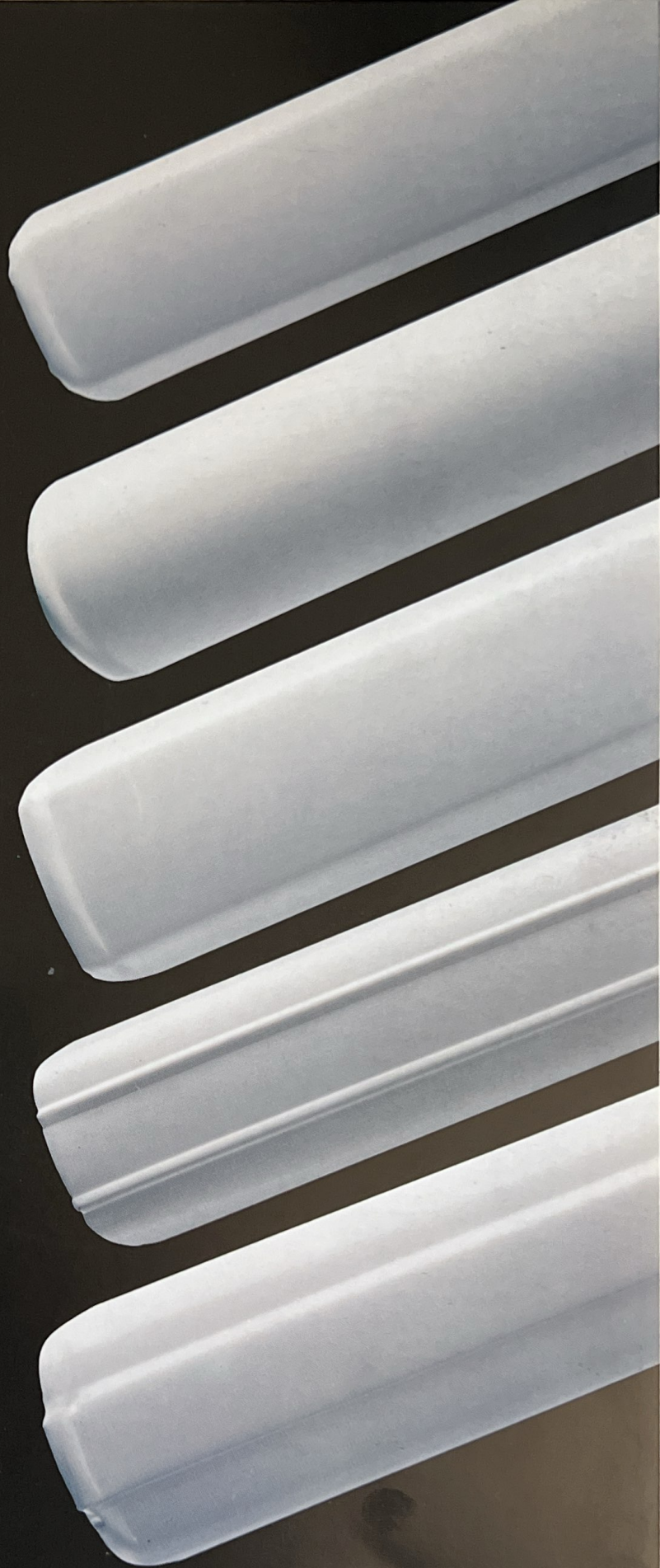
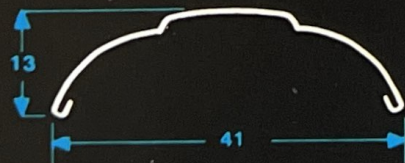

modello	punte chiuse	portafaro	attacco			aste		
			normale	cristina	BS	a filo esterne	a filo interne	piatte
3R 35	•			•		•	•	
T 36	•			•		•		
C 38	•	•		•		•	•	•
3R 38	•	•		•		•	•	•
61 S	•	•	•	•		•		



T 65

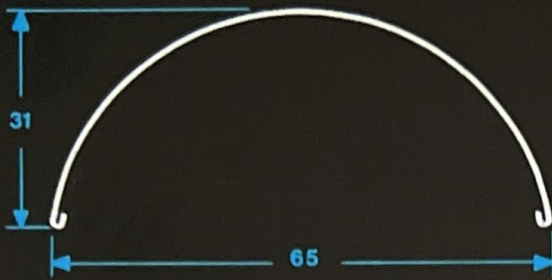

P 65

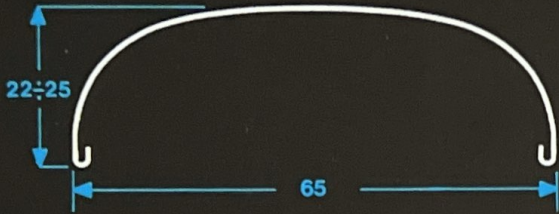

P 70

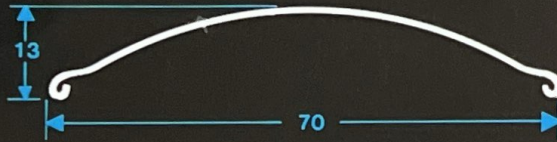

Cross 78

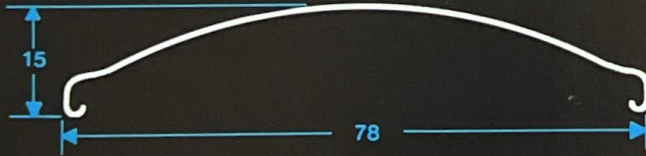

3R 65

NEW

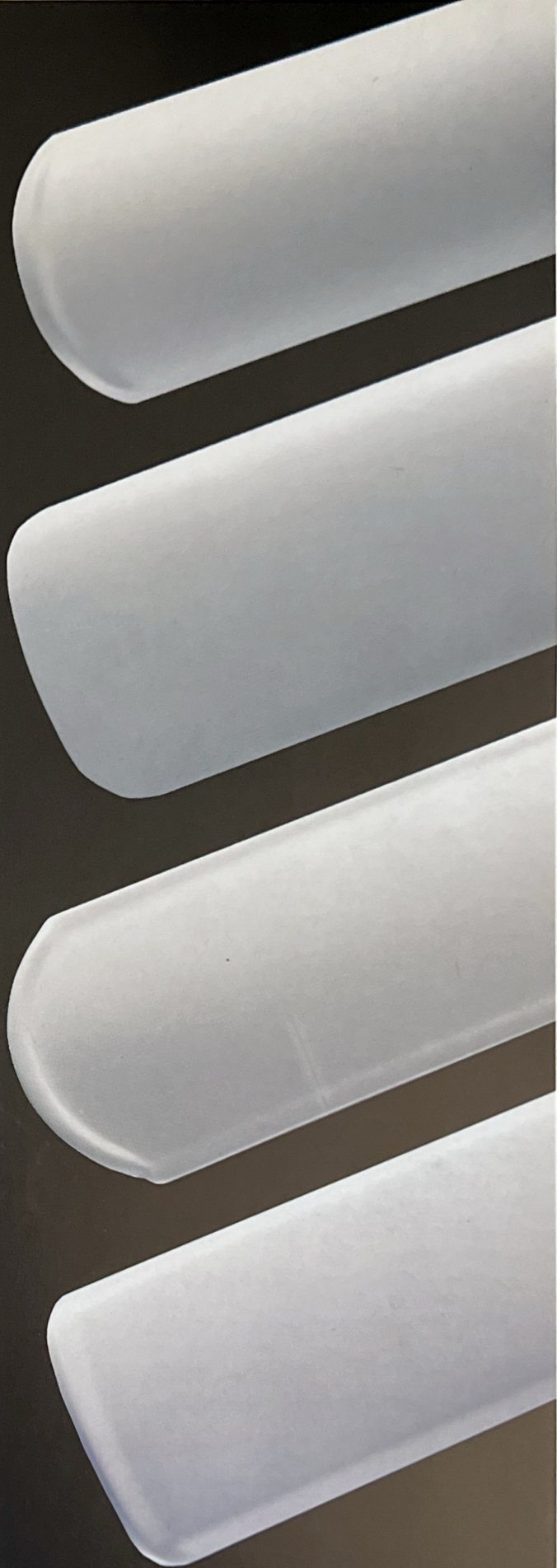
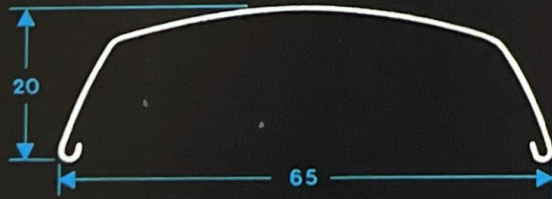

modello	punte chiuse	portafaro	attacco			aste		
			normale	cristina	BS	a filo esterne	a filo interne	piatte
T 65	•	•			•			•
P 65								•
P 70	•							•
Cross 78	•							
3R 65							•	



parafanghi anteriori

- a) Alettina "R"
 - b) Ventaglio
 - c) Aletta media
 - d) Aletta alla forcella
- } solo per ruote 26"-28"



corrazzature	3R 51 Maino 50	3R 55 WR 55	Viaggio oro B 56	mod. 90 mod. 62	Olanda Ganna sport	mod. 89	mod. 75	mod. 94
a	•	•	•	•	•	•	•	•
b		•	•	•	•	•		•
c		•	•	•		•	•	•
d		•	•	•		•	•	•



aste a filo

- In trafilato ϕ 4 mm. di ferro con finiture: grezza, zincocromata, cromata.
- Di alluminio con finiture: anodizzata, lucida, satinata, nera.
- Di acciaio INOX AISI 430.

No

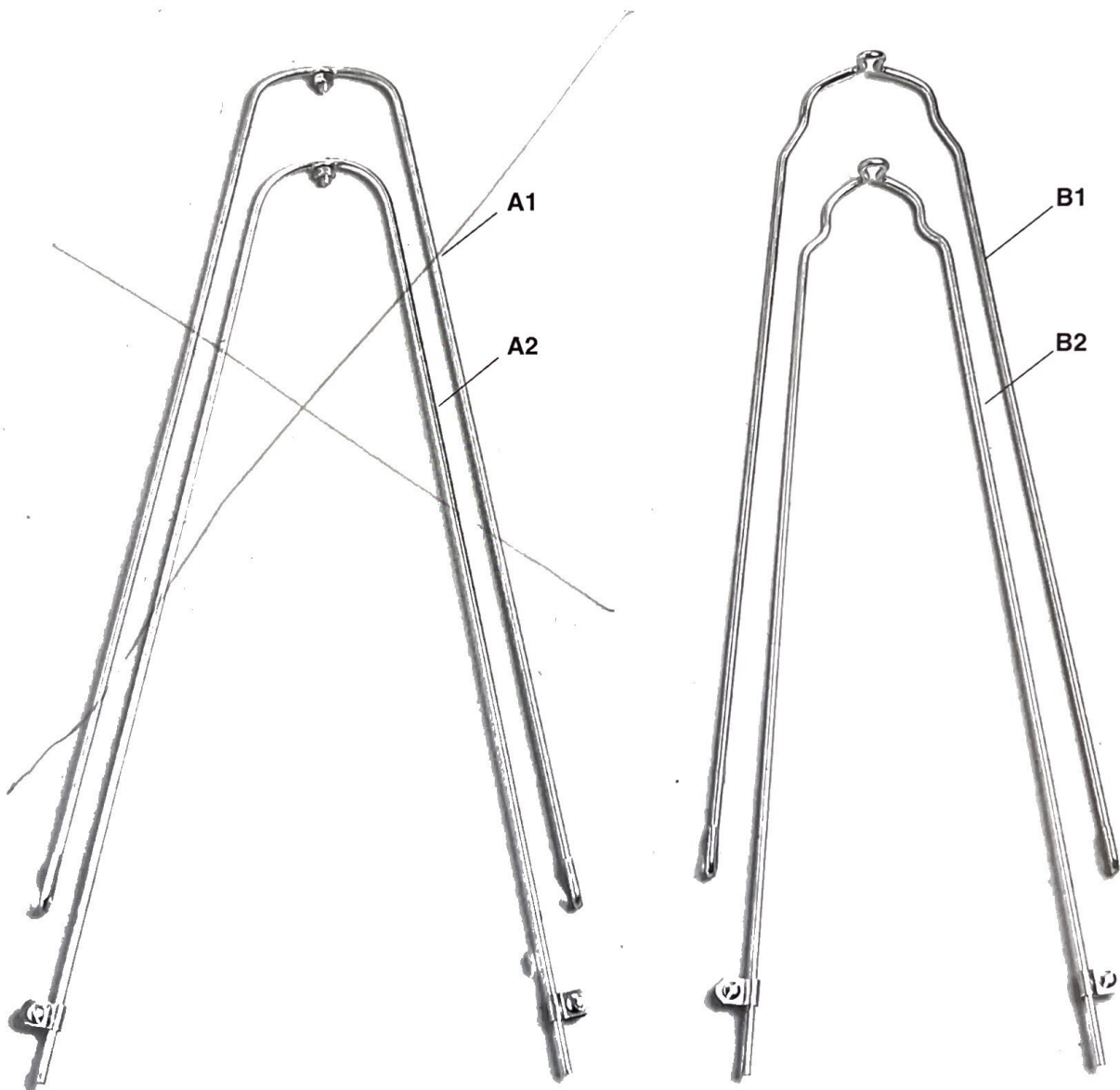

A 1	esterne con vite saldata
A 2	esterne con vite saldata
B 1	interne con tre occhielli
B 2	interne con un occhiello centrale più due fascette inox

A1 e A2 materiale:
ferro

B1 e B2 materiale:
ferro
alluminio
inox



aste a filo

- In trafilato \varnothing 4 mm. di ferro con finiture: grezza, zincocromata, cromata.
- Di alluminio con finiture: anodizzata, lucida, satinata, nera.
- Di acciaio INOX AISI 430.

aste in piattina

- Realizzabili nelle versioni a tubo aperto, imbutita.
- Finiture: ferro grezzo, zinco cromato, cromata, INOX AISI 430.
- Per attacco alla vite o al mozzo.



- | | |
|---|-------------------|
| A | esterna |
| B | interna |
| C | cristina |
| D | normale filettata |

A e B Stampate sagomate esterne e a piastrine per attacco a boccole, interne con o senza occhielli.

C Stampate a V senza filettatura per attacco Cristina.

D Stampate a V con filettatura per attacco normale.



parafanghi bastia r.r.l.

20080 ZIBIDO Loc. SAN GIACOMO
(MILANO) ITALY
SEDE E STABILIMENTO
VIA PAPA GIOVANNI XXIII, 3
Tel. (02) 90002329 - 90002862
FAX (02) 90002911

parti del parafango e misure da definire

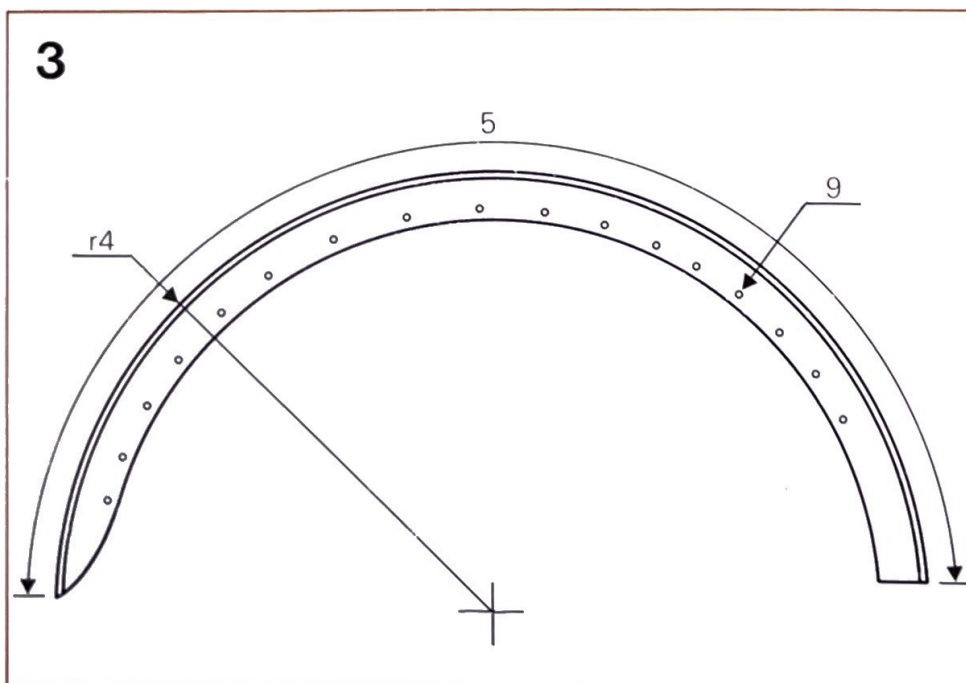
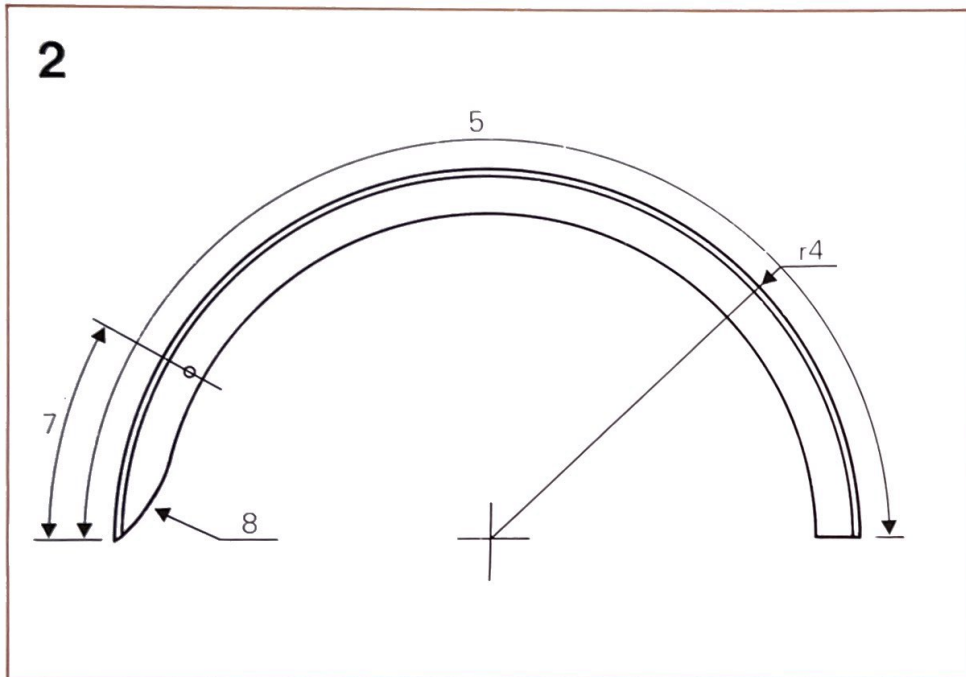
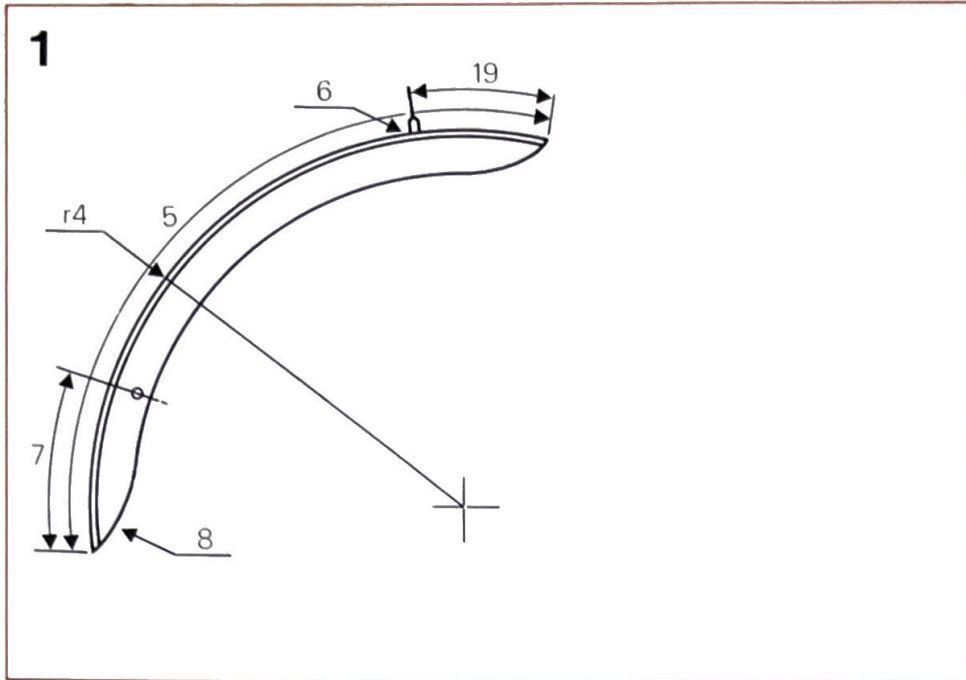

- Mudguards parts and measures choose
- Parts de garde-boues
- Schutzblechteile und Massenauswahl

- | | |
|--|---|
| 1 anteriore.
Front.
Avant.
Vorder. | 12 asta filo esterno.
Extern wire stay.
Tringle en fil
exterieur.
Üblaufstrebe |
| 2 posteriore uomo.
Rear man.
Arriere homme.
Hinter, Herren. | 13 asta filo interno.
Inside wire stay.
Tringle en fil
interieur.
Unterlaufstrebe |
| 3 posteriore donna.
Rear woman.
Arriere dame.
Hinter, Damen. | 14 asta piatta 1/2 tubo.
Pressed stay
round.
Tringle platte
tube.
Flachstrebe |
| 4 raggio esterno.
Extern ray.
Rayon exterieur.
Äussere Speiche. | 15 dadi normali.
Normal nuts.
Serre tringle
normale.
Strebeklemmschraube normal |
| 5 lunghezza totale.
Length total.
Developpe total.
Totallänge. | 16 morsetto normale.
Cristina clamp.
Serre tringle
normale.
Cristina.
Strebeklemmschraube normale |
| 6 squadretta.
Support.
Equerre.
Stütze. | 17 colonnetta normale.
Pivot.
Pivot.
Strebeklemmschraube normale |
| 7 posizione asta.
Stay position.
Position tringle.
Stellung der Strebe. | 18 attacco piatto.
Plate junction.
Serre tringle
plate.
Briede mit
befestigung
Plättchen. |
| 8 punte bordate.
End bonded.
Pointe rabattue.
Sicherheitsbördelung. | 19 posizione squadretta normale.
Support position.
Position equ.
Stellung der Stütze |
| 9 fori paraveste.
Holes for dressguards.
Trous parajupe.
Damenradnetze
Löcher. | 20 fori BS per attacchi C.
Holes BS for
clamps.
Trous pour
tringle Cristina.
BS Löcher
Cristina-Platte |
| 10 asta filo filettata.
Threaded wire stay.
Tringle en fil avec
filet.
Gewindestrebe. | |
| 11 aste filo Cristina.
Cristina wire stay.
Tringle en fil Cristina.
Cristina strebe. | |



parafanghi linea ITALIA

- Mudguards Italian style
- Garde-boues modele Italie
- Italien Schutzbleche

normali
a ponticelli

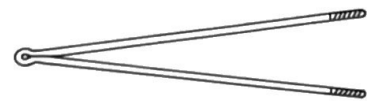
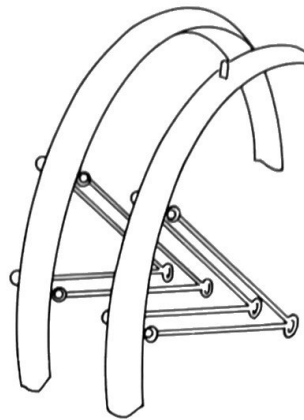

10

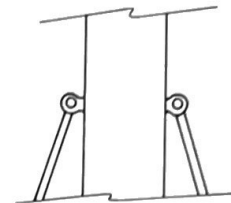

15

Cristina
a ponticelli

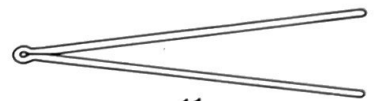
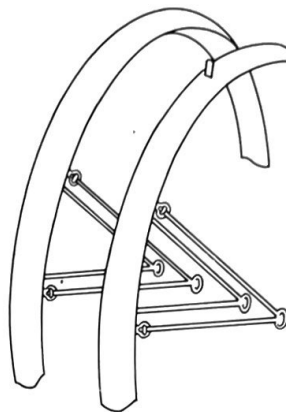

11

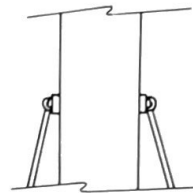

16

fori BS
per morsetto
Cristina

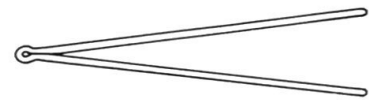
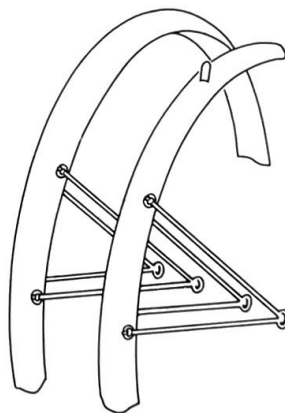

11



20



16

parafanghi tipo EXPORT

- Mudguards export line
- Garde-boues modele exportation
- Export-Schutzbleche

parafango
per aste
esterne

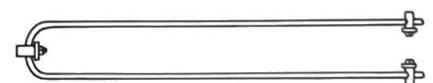
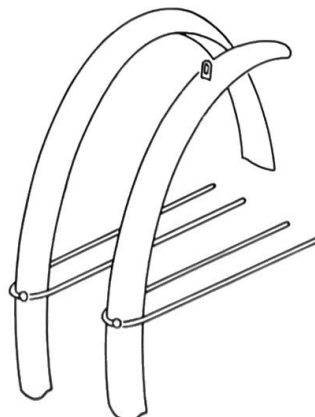

12



17



Mountain Bike & City Bike

per ruote di 16"-20"-24"-26"
modelli da 42 a 70 mm. di sezione

lungo

- per il 1° equipaggiamento con aste piatte



3/4 - eco

- per il montaggio senza aste

lungo

- per il 1° equipaggiamento con aste a filo Z/c e alluminio anodizzato,
- complete di viteria o con occhielli











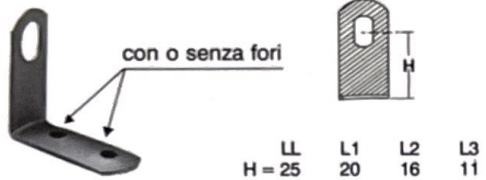
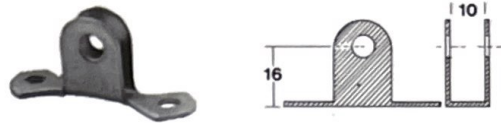
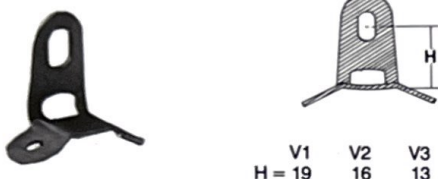

parafanghi bartia s.r.l.

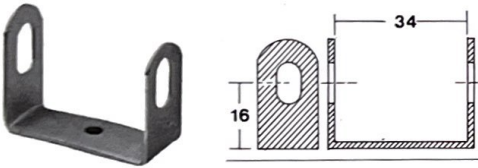
20080 ZIBIDO Loc. SAN GIACOMO
(MILANO) ITALY
SEDE E STABILIMENTO
VIA PAPA GIOVANNI XXIII, 3
TEL. (02) 90002329 - 90002862
FAX (02) 90002911

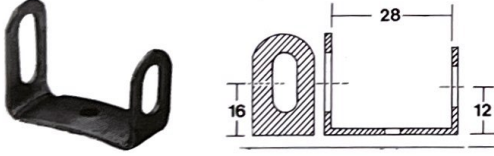
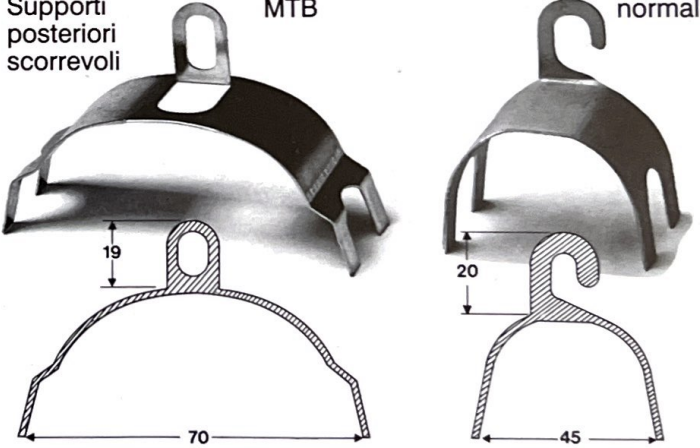
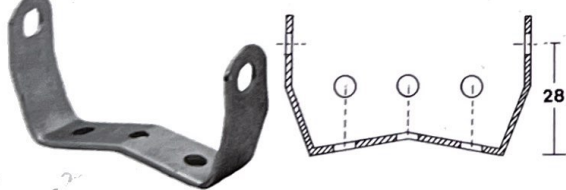
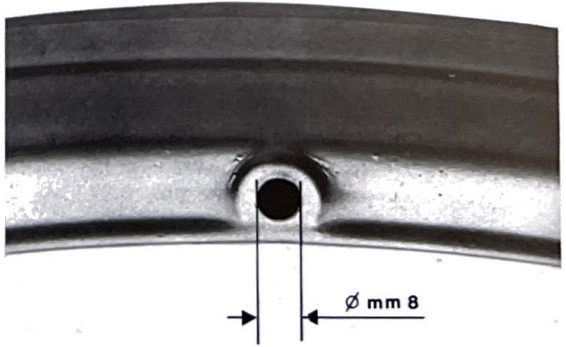
attacchi

<p>Squadretta L</p>  <p>con o senza fori</p> <p>LL L1 L2 L3 H = 25 20 16 11</p>	<p>Portafaro A</p>  <p>16 10</p>
<p>Squadretta V anteriore della forcella</p>  <p>V1 V2 V3 H = 19 16 13</p>	<p>Portafaro B</p>  <p>12 15</p>
<p>Squadretta T anteriore della forcella</p>  <p>18</p>	<p>Attacco FIV esterno In acciaio INOX</p>  <p>17</p>
<p>Cross A</p>  <p>16 34</p>	<p>Attacco FIV interno In alluminio</p>  <p>17</p>
<p>Cross B</p>  <p>16 28 12</p>	<p>Supporti posteriori scorrevoli</p> <p>MTB normale</p>  <p>19 20 70 45</p>
<p>Cross C</p>  <p>28</p>	<p>Foro BS per morsetto "Cristina"</p>  <p>Ø mm 8</p>
<p>Traversini</p> <p>"Cristina"</p> <p>Normale</p> 	



3R 42

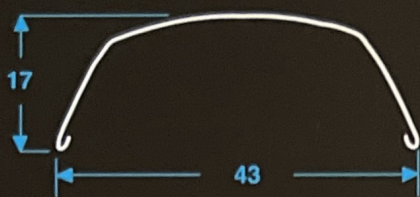

T 42

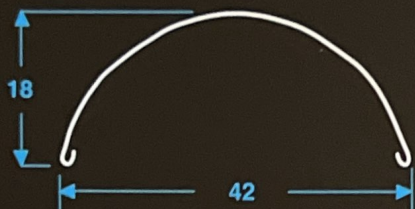

K 45

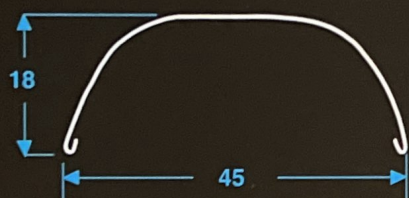

CB 51

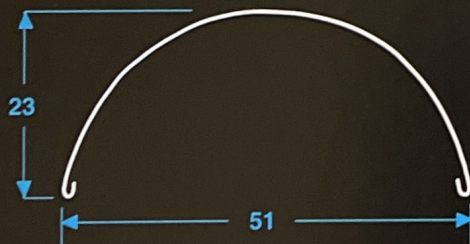

MTB 60

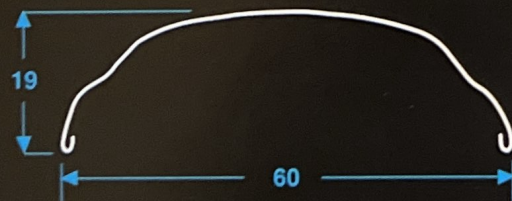

modello	punte chiuse	portafaro	attacco			aste		
			normale	crisina	BS	a filo esterne	a filo interne	piatte
3R 42	•	•	•	•		•	•	•
T 42	•	•	•	•		•	•	•
K 45	•	•				•	•	•
CB 51	•	•	•	•		•	•	•
MTB 60	•	•				•	•	•