



**PARAFANGHI BASTIA s.r.l.**

Via Concordia, 2  
20090 Assago (MI) - Italy

Tel. +39 02 45702721

Fax +39 02 45713658

E-mail: [parafanghi.bastia@tiscalinet.it](mailto:parafanghi.bastia@tiscalinet.it)

[www.parafanghibastia.com](http://www.parafanghibastia.com)



PARAFANGHI BASTIA, costruttore leader nel settore dei parafanghi con una esperienza di oltre 80 anni, offre oggi una linea di modelli che sono i più imitati dalle case concorrenti.

La capacità produttiva è di circa 6.000.000 di unità all'anno, ripartiti tra modelli per ciclo, ciclomotori, moto e derivati, nei materiali acciaio INOX, ferro grezzo, verniciato, cromato e plastificato, alluminio anodizzato.

PARAFANGHI BASTIA realizza modelli propri come pure produce su disegno della clientela. Esporta in tutto il mondo e si indirizza soprattutto alla grande produzione e distribuzione. Conserva inalterata nel tempo la costanza della qualità dei suoi prodotti e delle materie prime utilizzate.

**RENDETECI QUESTA SCHEMA CON LE VOSTRE MISURE PARTICOLARI**  
**PLEASE SEND US BACK THIS SCHEMA WITH SPECIFICATIONS REQUIRED**

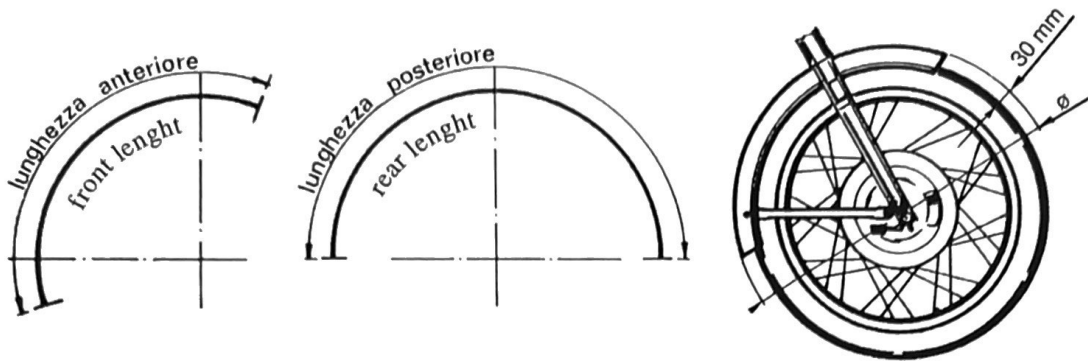

**PROFILO IN SEZIONE**  
**PROFIL IN SECTION**

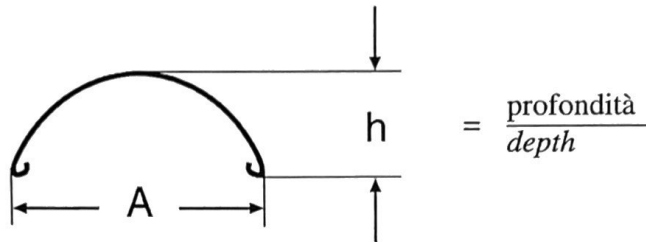

**PARAFANGO ANTERIORE**  
**FRONT MUDGUARD**

**PARAFANGO POSTERIORE**  
**REAR MUDGUARD**

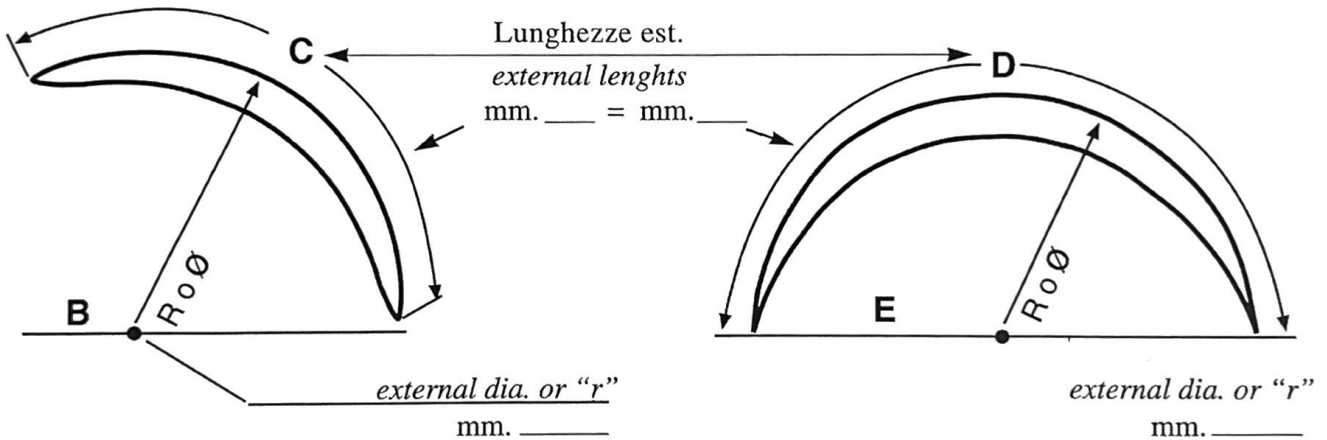

**SPECIFICAZIONI / SPECIFICATIONS**

**NS. MODELLO**  
**OUR MODEL**

**ANT. / FRONT** = mod. \_\_\_\_\_  
**POST. / REAR** = mod. \_\_\_\_\_

**MATERIALE** Alluminio   
**MATERIAL** Alloy

Ferro grezzo   
 Raw steel

Acciaio inox   
 Stainless stell

**FINITURA** Lucidato   
**FINISH** Polished

Non lucidato   
 Unpolished

Grezzo   
 Raw

**PUNTE** Bordata aperta   
**BEADING** Bonded open

Bordata chiusa   
 Bonded closed

Quantità minima pezzi per modello N° \_\_\_\_\_

Minimum quantity for each one model N° \_\_\_\_\_



**parafanghi bastia s.r.l.**

PARAFANGHI PER CICLI MOTOCICLI CICLOMOTORI  
VIA CONCORDIA, 2 - 20090 ASSAGO (MILANO) - ITALY  
Tel. +39 02 45702721 - Fax +39 02 45713658  
E-mail: parafanghi.bastia@tiscali.it  
www.parafanghibastia.it

# PARAFANGHI ALLUMINIO "VETERAN"

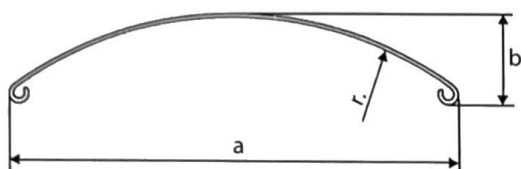

## CROSS

ns. modello	a	b	Nastro
T 5060 A	82	16	100X1
T 5060 B	92	22	120X1
AT 5070/1	102	24	130X1,5
AT 5070/2	114	34	150X1,5
AT 160	160	36	195X1,5
AT 180	180	46	225X1,5

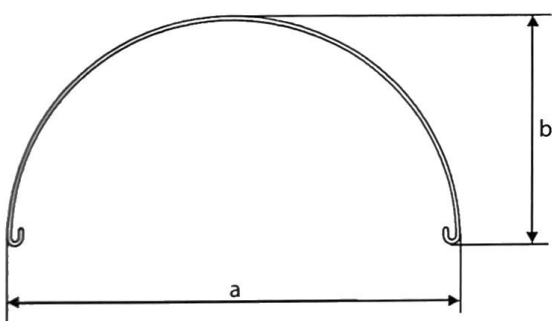

## TONDO

ns. modello	a	b	Nastro
T 5040	105	32	140X1
T 5060	112	37	150X1
AT 5070/3	123	43	170X1,5
AT 5070/4	130	55	195X1,5

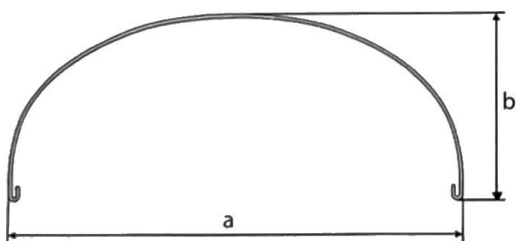

## SEMITONDO

ns. modello	a	b	Nastro
PP 3070	120	40	170X1,5
AP 3100	140	51	195X1,5
AP 130	130	35	170X1,5



parafanghi bastia s.r.l.

# COPRICORONA PER BETONIERE PARAFANGHI PROFILATI E CARTER PER MACCHINE EDILI

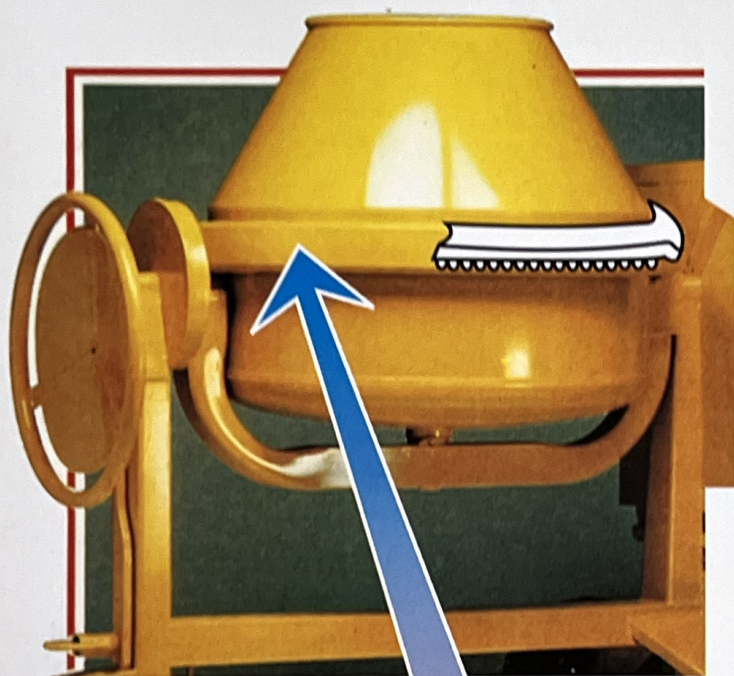

- IN ACCIAIO GREZZO ZINCATO O INOX AISI 430 SPESSORE 10/10.
- QUALUNQUE DIAMETRO E SVILUPPO FINO A 360°.
- ANCHE COMPLETI DI STAFFE FISSAGGIO E PASSAGGIO PER INGRANAGGI. SU VS. DISEGNI ESCLUSIVI.





## COPRICORONA PER BETONIERE SAGOMATI STANDARD

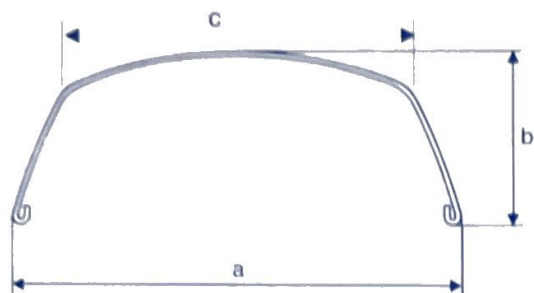

nostro codice	a	b	c	Betoniere
<b>S9060</b>	76	37	56	da 180 a 250 lt

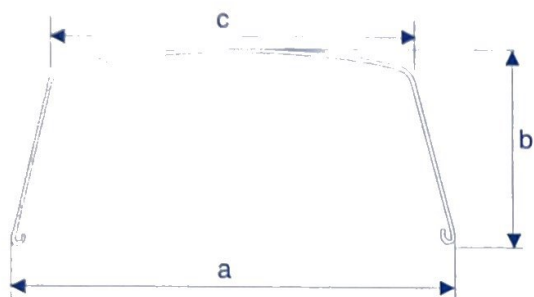

nostro codice	a	b	c	Betoniere
<b>S9300L</b>	118	50	90	da 300 a 600 lt

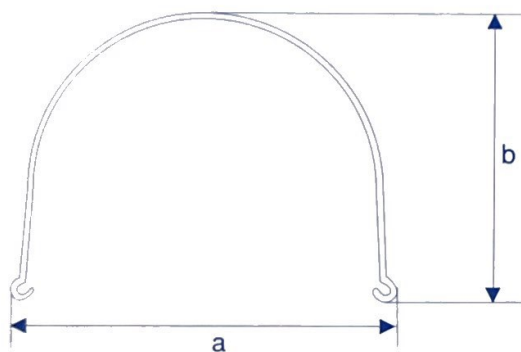

nostro codice	a	b	c	Betoniere
<b>T5140G</b>	100	70	—	da 400 a 600 lt



## SAGOMATI PER MOTOCARRI AUTOCARRI LEGGERI E RIMORCHI

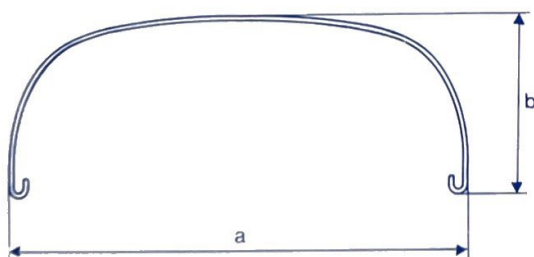

nostro modello	a	b	c
<b>P3080</b>	130	35	—
<b>P3110</b>	150	55	—

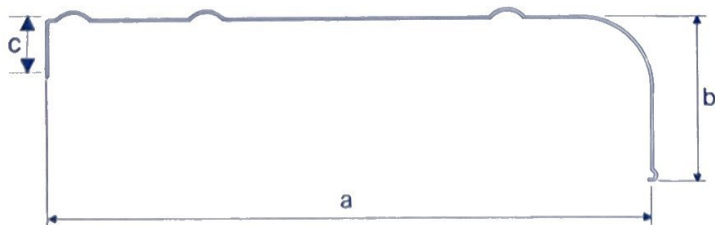

nostro modello	a	b	c
<b>S9220</b>	200	45	25
<b>S9230</b>	220	45	25



**parafanghi bastia s.r.l.**

Via Papa Giovanni XXIII - 20080 Zibido Loc. S. Giacomo (MI) - ITALY  
tel. 02 / 90002329 / 90002862 - Fax 02 / 90002911



produzione PIAGGIO

modello per ciclomotore

**CIAO-PX-SC**

anteriore/avant/front/hinter

cod.

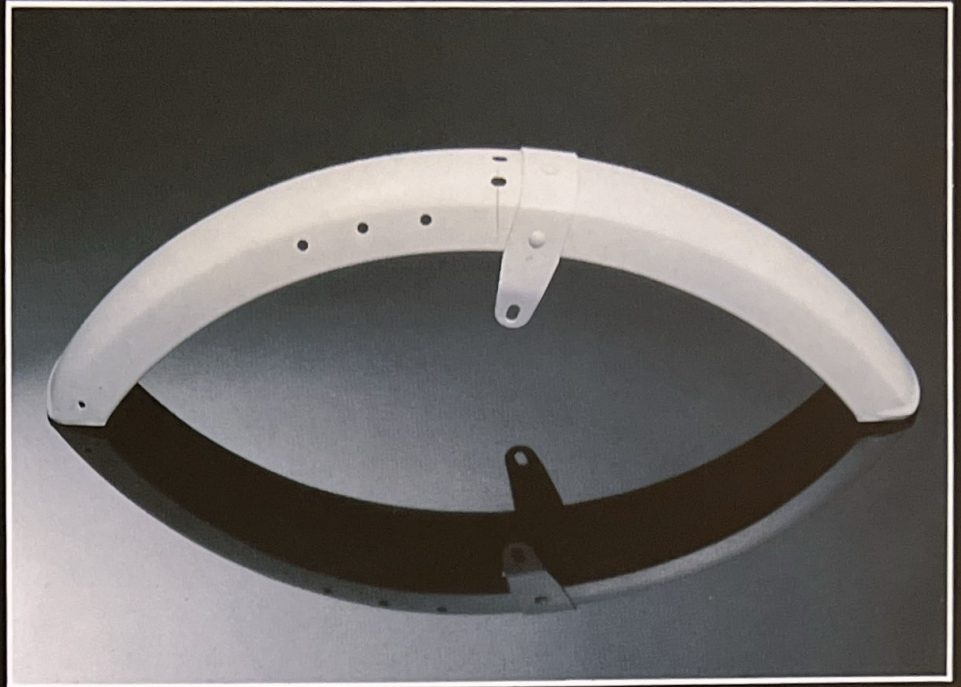

posteriore/arriere/rear/vorder

cod.



profilo

mod. S 9060

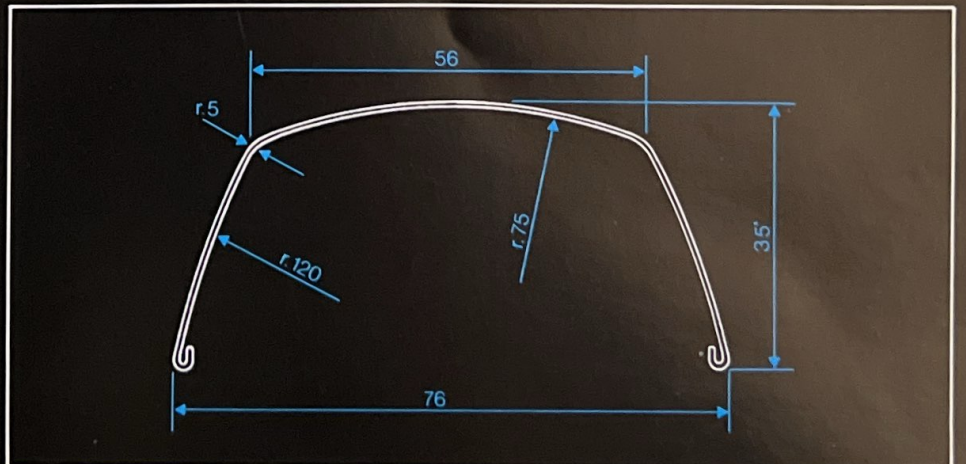



produzione PUCH

modello per ciclomotore

**PUCH MAXI**



posteriore/arriere/rear/vorder

cod.

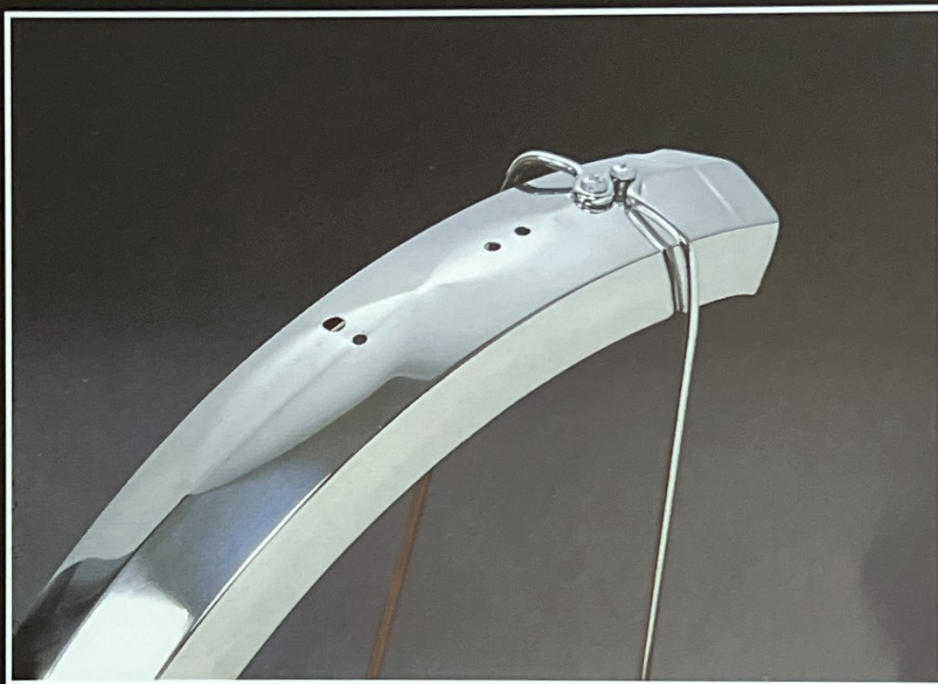

posteriore/arriere/rear/vorder

cod.

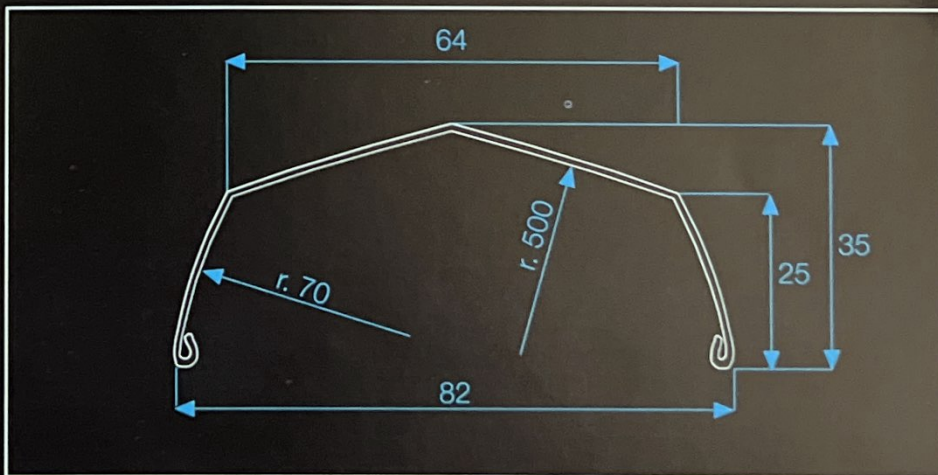

profilo

mod. S 9400



produzione PUCH

modello per ciclomotore

**PUCH MAXI**



anteriore/avant/front/hinter

cod.



anteriore/avant/front/hinter

cod.

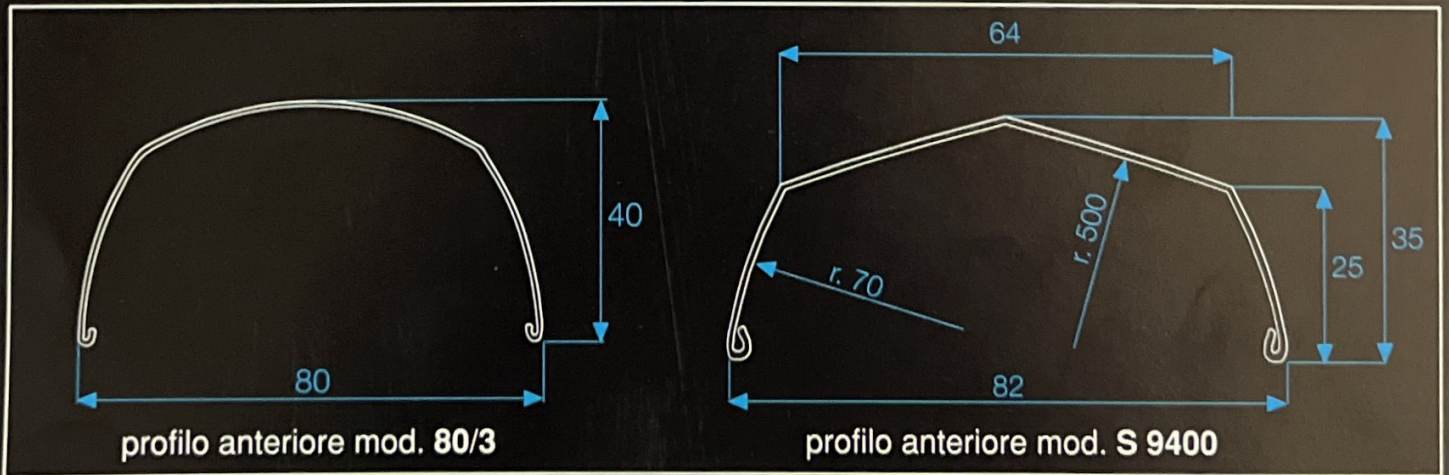



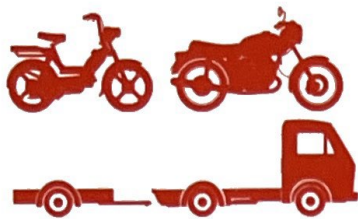

**parafanghi bastia s.r.l.**

20136 MILANO (ITALY)  
UFF. E STABILIMENTO  
VIA C. BALFO, 4  
TEL. (02) 545.23.98 - 593.107  
FAX (02) 55.150.144  
TELEX 310677/315648  
ASLOMB I, 573 BASTIA

**PARAFANGHI BASTIA s.r.l.**  
Via Papa Giovanni XXIII  
20080 Zibido Loc. S. Giacomo (MI)  
Cod. Fisc. 05801240150



## TONDO

ns. modello	a	b	
T 5000	70	35	
T 5010	80	35	
T 5020	85	35	
T 5030	90	45	
T 5040	105	45	
T 5050	106	55	
T 5060	112	50	
T 5070	123	55	
T 5090	136	53	

## CROSS

ns. modello	a	b	r
T 5060 A	82	16	67
T 5060 B	92	22	64
T 5060 C	102	24	69
T 5060 D	114	34	67
T 3050 A	90	16	85
T 3050 B	100	19	90

## PIATTO

ns. modello	a	b	
P 3000	65	22	
P 3030	100	32	
P 3080	130	35	
P 3110	150	55	

## SEMITONDO

ns. modello	a	b	
P 3040	110	45	
P 3050	110	30	
P 3060	135	51	
P 3070	120	43	
P 3090	146	43	
P 3100	140	45	
P 3120	180	56	

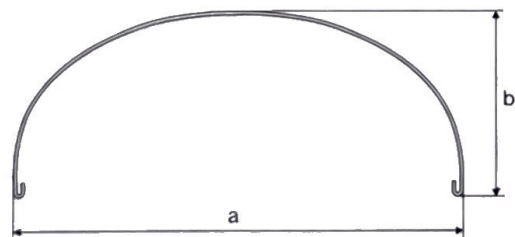
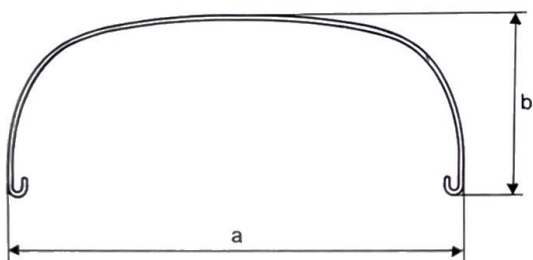
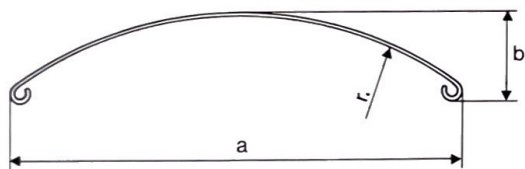
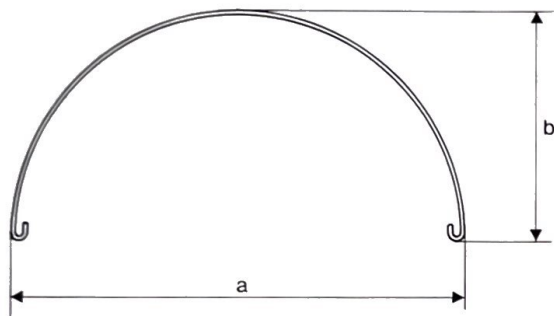



**parafanghi bastia s.r.l.**

20136 MILANO (ITALY)  
UFF. E STABILIMENTO  
VIA C. BALBO, 4  
TEL. (02) 545.26.98 - 593.107  
FAX (02) 55.180.144  
TELEX 310677/315648  
ASLOMB I. 573 BASTIA



## SAGOMATI

ns. codice	a	b	c	r/d	r/e	r/f	g
<b>S 1000</b>	82	42	60	95	55	—	—
<b>S 9270</b>	80	33	74	130	66	—	—
<b>S 9290</b>	78	36	59	49	59	—	—

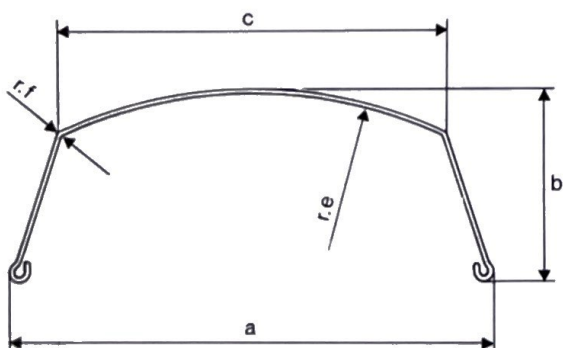
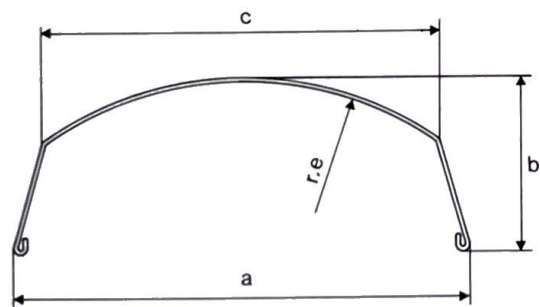
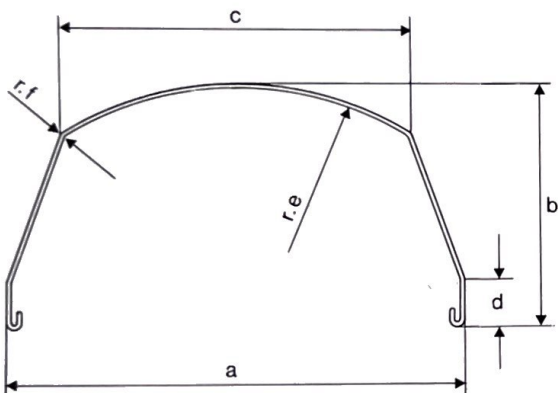
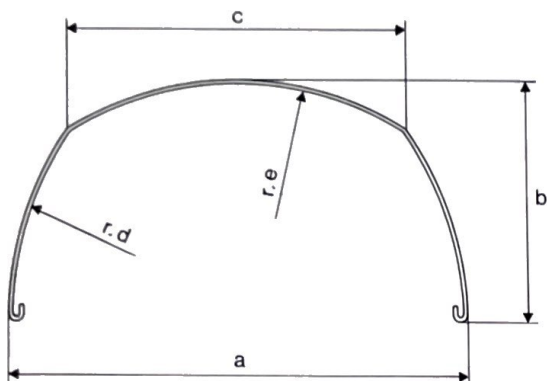

ns. codice	a	b	c	d	r/e	r/f	—
<b>S 1000 A</b>	80	42	60	—	55	—	—
<b>S 9230 A</b>	90	45	70	8	62	—	—
<b>S 9320</b>	135	50	112	10	210	6	—
<b>S 9360</b>	105	50	82	10	200	3	—
<b>S 9360 A</b>	100	35	82	8	200	3	—
<b>S 9300</b>	112	50	90	10	210	5	—

ns. codice	a	b	c	d	r/e	r/f	—
<b>S 9040</b>	76	29	62	—	70	—	—

ns. codice	a	b	c	d	r/e	r/f	—
<b>S 9120</b>	88	32	74	—	66	—	—
<b>S 9120 A</b>	80	20	74	—	66	—	—
<b>S 9180</b>	82	35	68	—	62	2	—
<b>S 9230</b>	92	45	70	—	62	—	—
<b>S 9300 A</b>	102	23	90	—	210	5	—



parafanghi bastia s.r.l.

20136 MILANO (ITALY)  
UFF. E STABILIMENTO  
VIA C. BALBO, 4  
TEL. (02) 543.26.98 - 593.107  
FAX (02) 54.180.144  
TELEX 314677315648  
ASLOMEN, 5/3 BASTIA

Via Papa XXIII  
20080 Zibido Loc. S. Giacomo (MI)  
Cod. Fisc. 05801240188

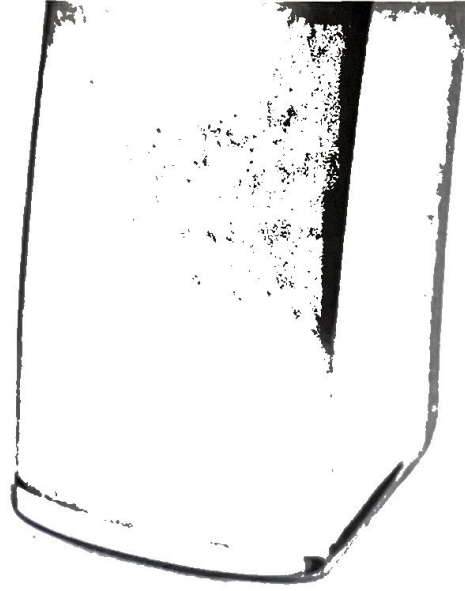

### SAGOMATI (seguito)

ns. codice	a	b	c	r/d	r/e	r/f	—
<b>S 9050</b>	70	25	55	100	70	6	—
<b>S 9060</b>	76	35	56	120	75	5	—
<b>S 9180 A</b>	86	40	68	100	62	2	—
<b>S 9270 A</b>	86	37	74	70	66	2	—
<b>S 9340</b>	90	30	77	112	140	6	—
<b>S 9380</b>	80	40	65	95	90	9	—

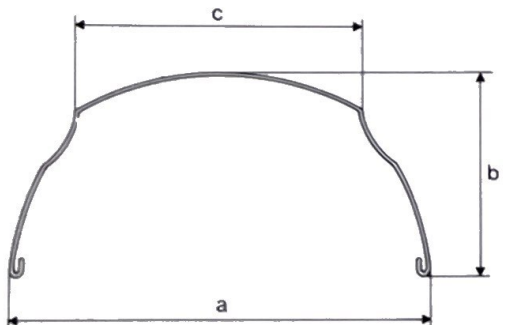
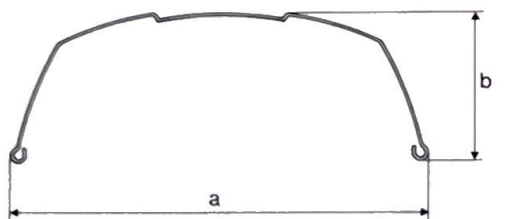
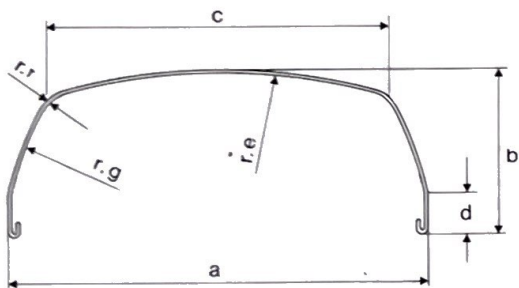
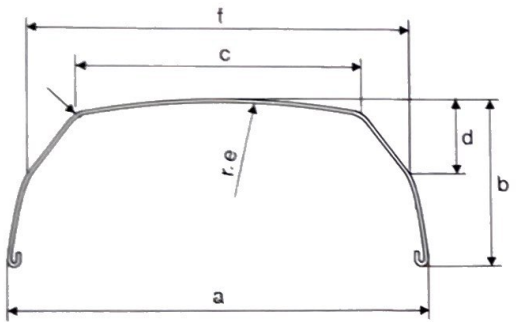
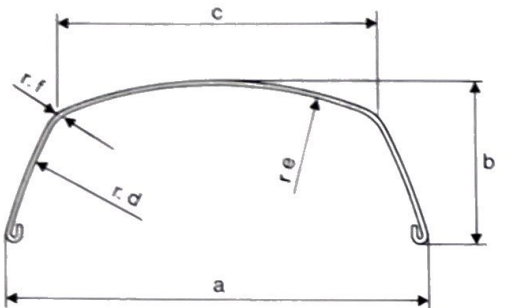

ns. codice	a	b	c	d	r/e	f	—
<b>S 9494</b>	85	34	58	15	220	80	—

ns. codice	a	b	c	d	r/e	r/f	r/g
<b>S 9340 A</b>	95	36	77	8	140	6	120

ns. codice	a	b	—	—	—	—	—
<b>S 9140</b>	95	40	—	—	—	—	—
<b>S 9150</b>	110	45	—	—	—	—	—

ns. codice	a	b	c	—	—	—	—
<b>S 9020</b>	75	40	56	—	—	—	—

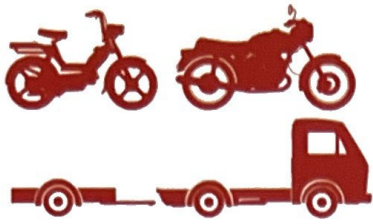

**parafanghi bastia s.r.l.**

20136 MILANO (ITALY)  
UFF. E STABILIMENTO  
VIA C. BALBO, 4  
TEL. (02) 545.26.98 - 593.107  
FAX (02) 55.180.144  
TELEX 310677/315648  
ASLOMB I. 573 BASTIA

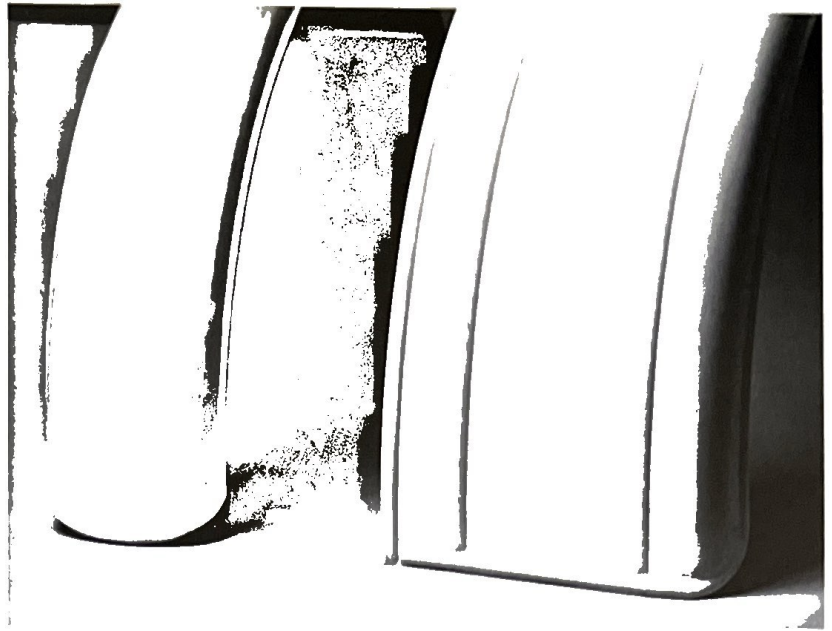

## SAGOMATO G

ns. codice	a	b	r/c	r/d	r/e	r/f	—
<b>S 9200 G</b>	104	37	95	30	—	—	—
<b>S 9260 G</b>	95	30	75	28	—	—	—
<b>S 9500 G</b>	83	27	75	20	—	—	—

ns. codice	a	b	r/c	r/d	—	—	—
<b>S 9210 G</b>	112	50	103	20	—	—	—

ns. codice	a	b	c	r/d	r/e	r/f	—
<b>S 9380 G</b>	80	40	65	90	95	9	—
<b>S 9280</b>	92	50	76	50	300	—	—

## SAGOMATI PER MOTOCARRI E AUTOCARRI LEGGERI

ns. codice	a	b	c	—	—	—	—
<b>S 9160</b>	170	70	92	—	—	—	—

ns. codice	a	b	c	—	—	—	—
<b>S 9220</b>	200	45	—	—	—	—	—
<b>S 9230</b>	220	45	—	—	—	—	—

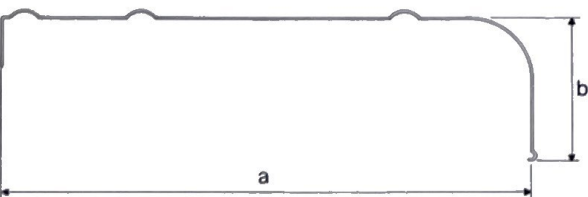
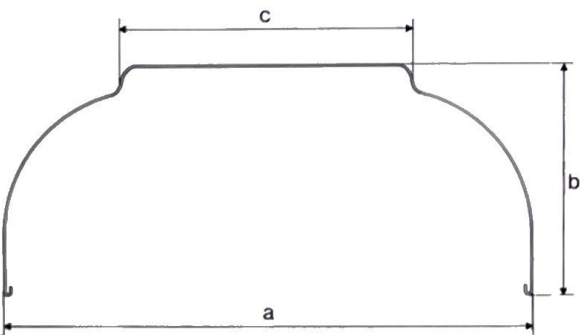
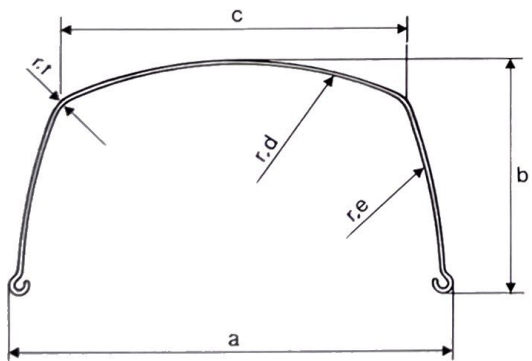
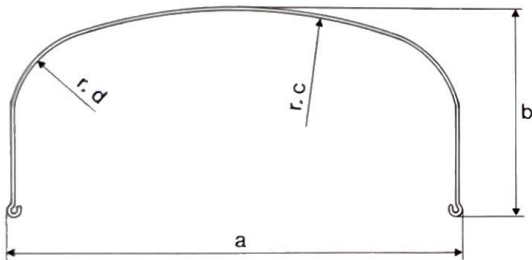
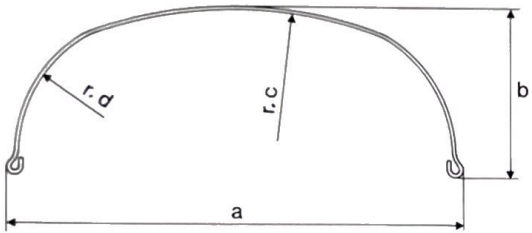



**parafanghi bastia s.r.l.**

Parafanghi Bastia S.r.l.  
Via F.lli. Cervini, XXIII  
20080 Zibido Lucina, Arezzo (AR)  
Cod. Fisc. 0581240150

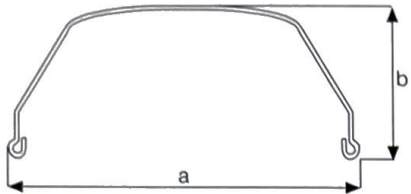

ns. codice	a	b	c	d	r.c	r.d	—
<b>S 70 TR</b>	70	30	—	—	—	—	—

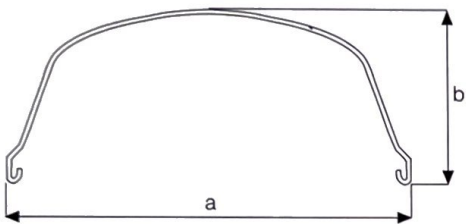

ns. codice	a	b	c	d	r.c	r.d	—
<b>S 80 TR</b>	80	35	—	—	—	—	—

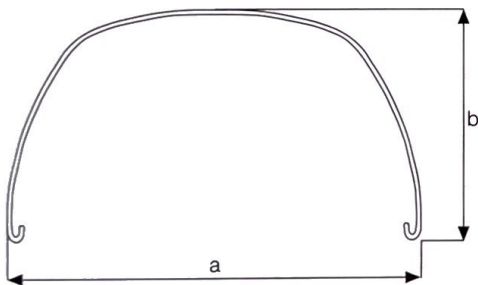

ns. codice	a	b	c	d	r.c	r.d	—
<b>S 80/1 TR</b>	80	47	—	—	—	—	—

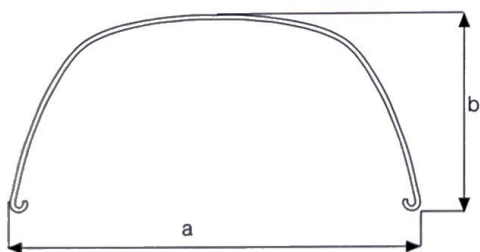

ns. codice	a	b	c	d	r.c	r.d	—
<b>S 80/3 TR</b>	80	40	—	—	—	—	—



parafanghi bastia s.r.l.

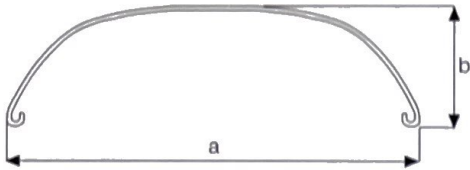

ns. codice	a	b	c	d	r.c	r.d	—
<b>S 85 TR</b>	85	23	—	—	—	—	—

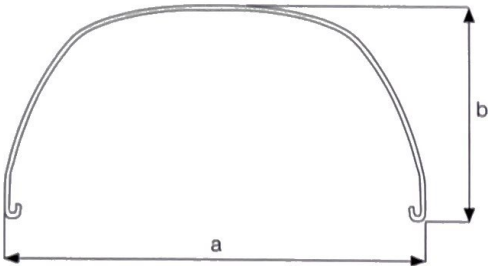

ns. codice	a	b	c	d	r.c	r.d	—
<b>S 85/1 TR</b>	85	45	—	—	—	—	—

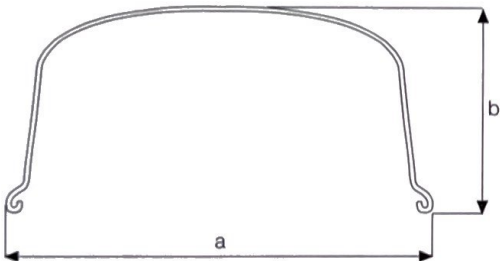

ns. codice	a	b	c	d	r.c	r.d	—
<b>S 85/2 TR</b>	85	42	—	—	—	—	—

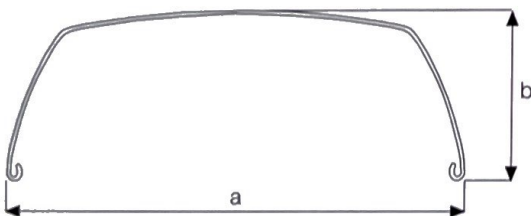

ns. codice	a	b	c	d	r.c	r.d	—
<b>S 88 TR</b>	88	34	—	—	—	—	—



**parafanghi bastia s.r.l.**

PARAFANGHI BASTIA S.r.l.  
Via Papa Giovanni XXIII  
20090 Zibido Loc.S.Giacomo (MI)  
Cod. Fisc. 05801240150

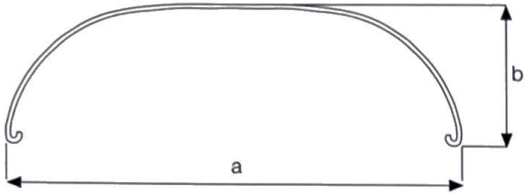

ns. codice	a	b	c	d	r.c	r.d	—
<b>S 90 TR</b>	90	30	—	—	—	—	—

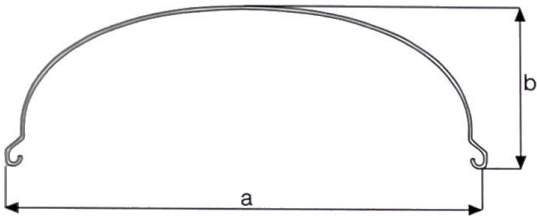

ns. codice	a	b	c	d	r.c	r.d	—
<b>S 90/1 TR</b>	90	30	—	—	—	—	—

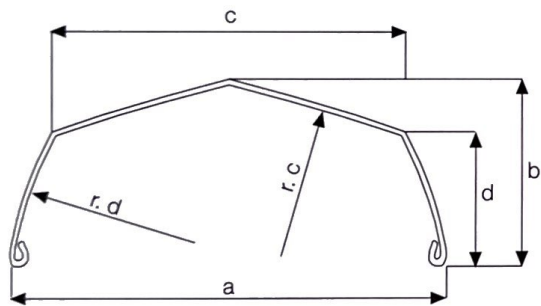

ns. codice	a	b	c	d	r.c	r.d	—
<b>S 9400</b>	82	35	64	25	500	70	—

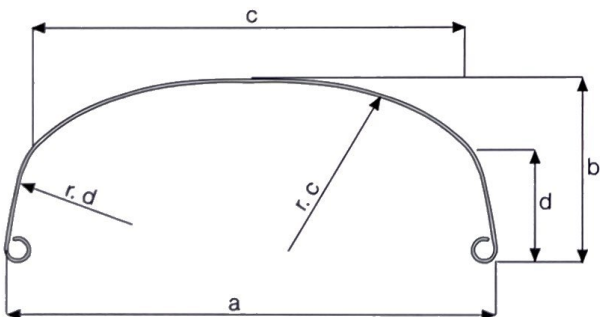

ns. codice	a	b	c	d	r.c	r.d	—
<b>S 9420</b>	90	34	83	19	71	80	—

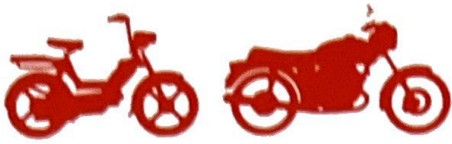

parafanghi bastia s.r.l.

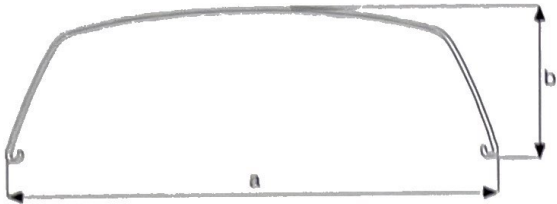

ns. codice	a	b	c	d	r.c	r.d	—
<b>S 92 TR</b>	92	30	—	—	—	—	—

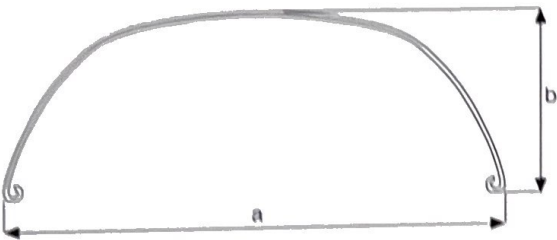

ns. codice	a	b	c	d	r.c	r.d	—
<b>S 100 TR</b>	100	38	—	—	—	—	—

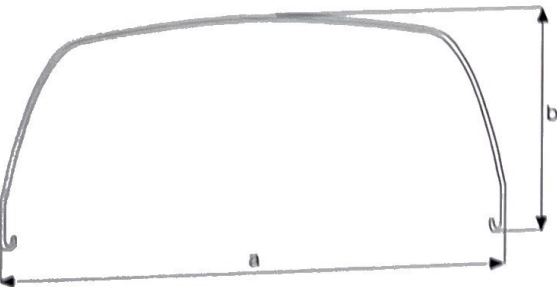

ns. codice	a	b	c	d	r.c	r.d	—
<b>S 100/1 TR</b>	100	45	—	—	—	—	—

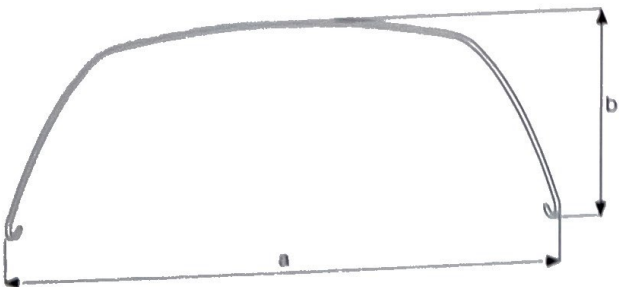

ns. codice	a	b	c	d	r.c	r.d	—
<b>S 110/1 TR</b>	110	43	—	—	—	—	—





produzione PEUGEOT

modello per ciclomotore

**SP 103**

anteriore/avant/front/hinter

cod.



posteriore/arriere/rear/vorder

cod.

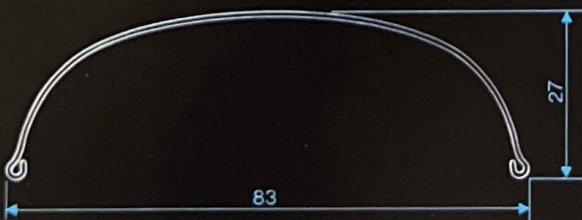

profilo anteriore mod. S 9500 G

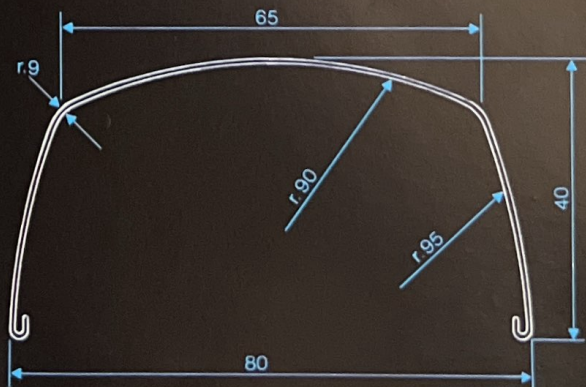

profilo posteriore mod. S 9380



PRODUZIONE PEUGEOT

modello per ciclomotore

**MVL 103**

anteriore / avant / front / hinter

cod.



posteriore / arriere / rear / vorder

cod.



profilo

mod. S 9380

