



produzione PIAGGIO

modello per ciclomotore

CIAO-PX-SC

anteriore/avant/front/hinter

cod.

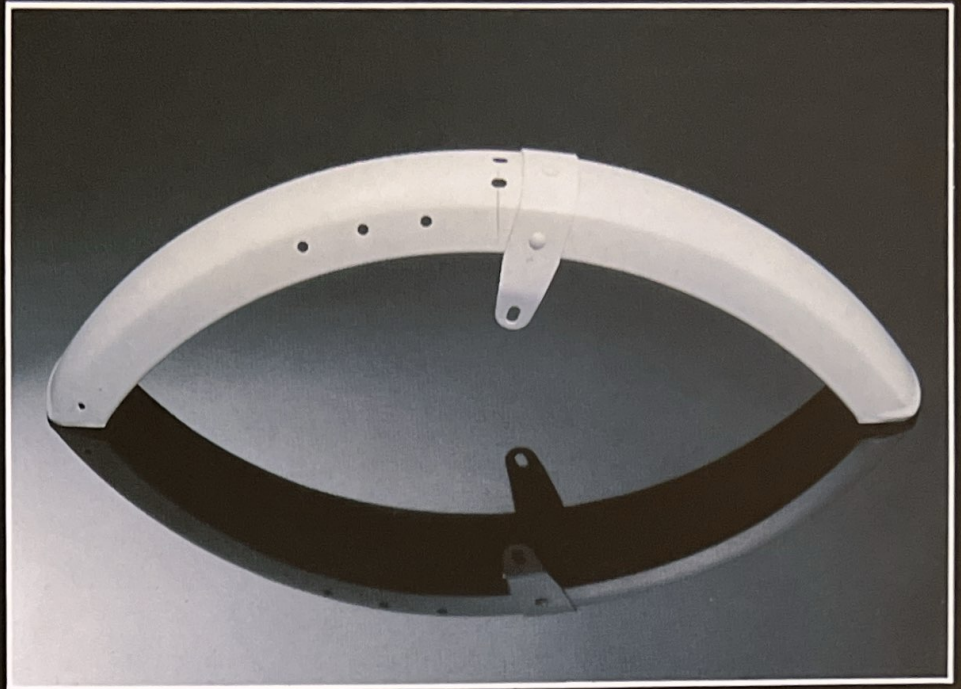

posteriore/arriere/rear/vorder

cod.

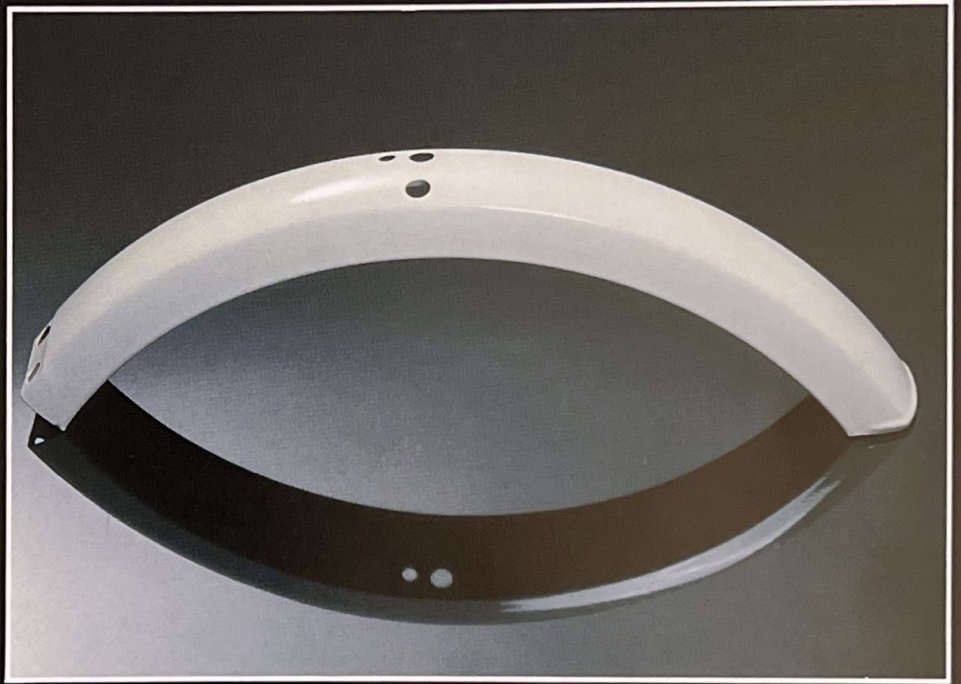

profilo

mod. S 9060

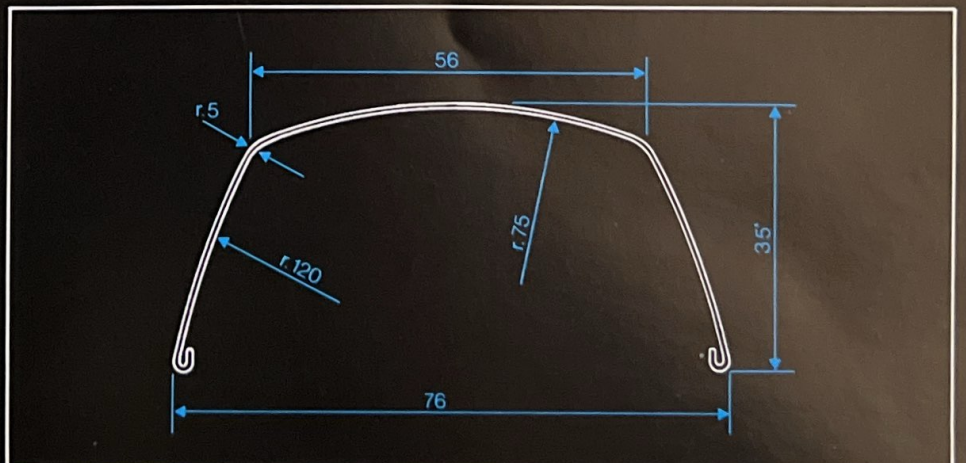



modello per ciclomotore

PUCH MAXI

posteriore/arriere/rear/vorder

cod.



posteriore/arriere/rear/vorder

cod.

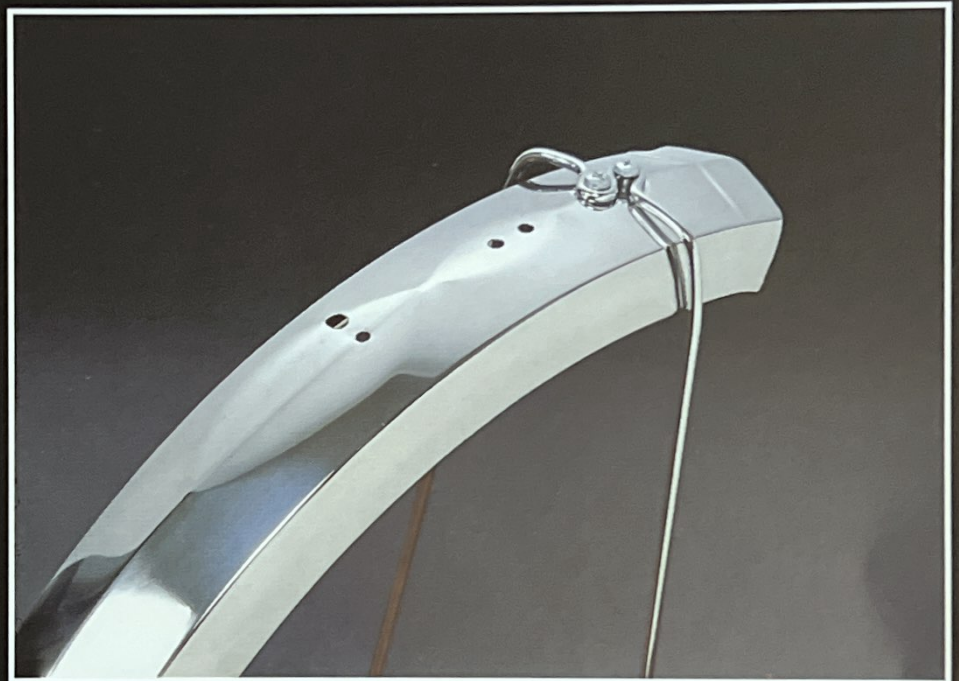

profilo

mod. S 9400

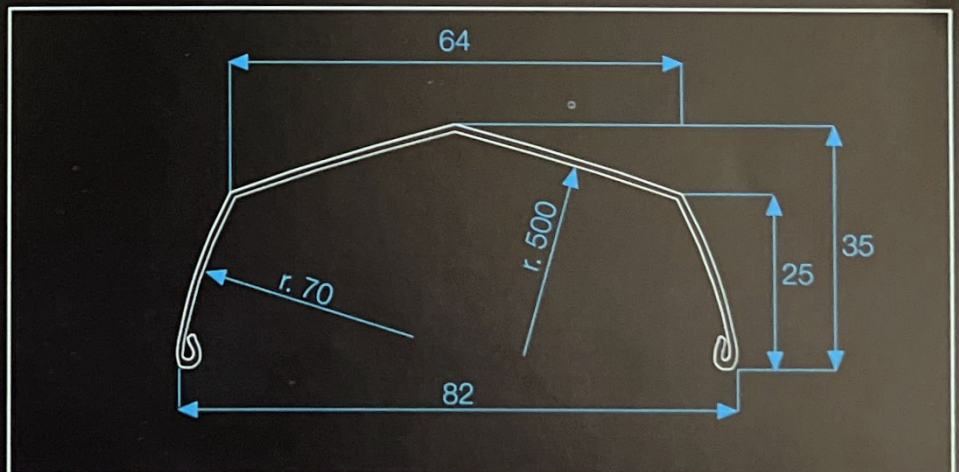



produzione PUCH

modello per ciclomotore

PUCH MAXI



anteriore/avant/front/hinter

cod.



anteriore/avant/front/hinter

cod.

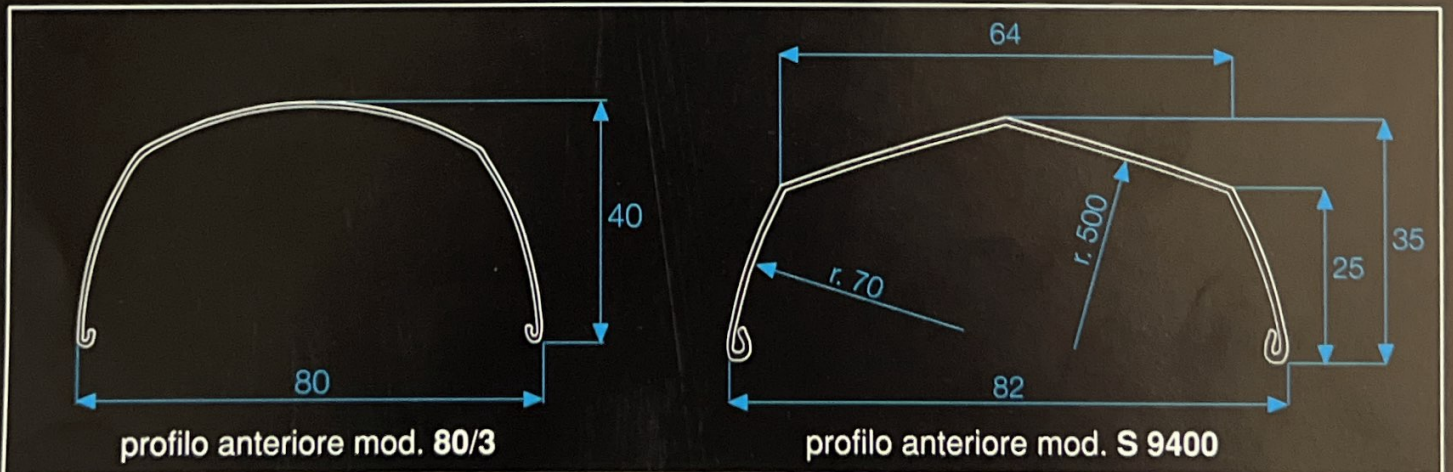

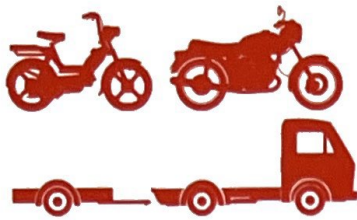

parafanghi bastia s.r.l.

20136 MILANO (ITALY)
UFF. E STABILIMENTO
VIA C. BALFO, 4
TEL. (02) 545.27.98 - 593.107
FAX (02) 55.170.144
TELEX 310677/315648
ASLOMB I 573 BASTIA

PARAFANGHI BASTIA s.r.l.
Via Papa Giovanni XXIII
20080 Zibido Loc. S. Giacomo (MI)
Cod. Fisc. 05801240150

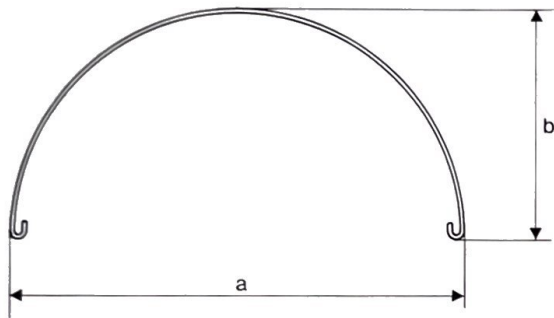
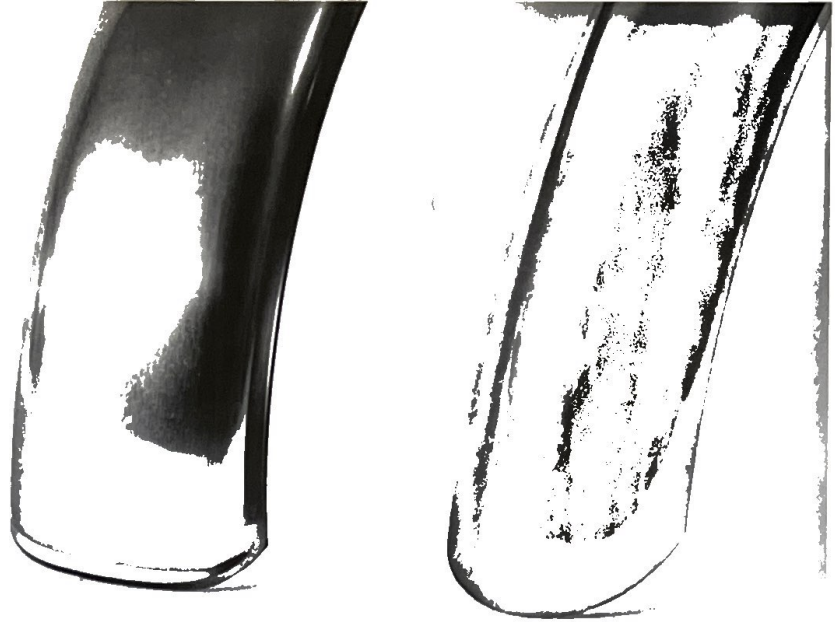

TONDO

ns. modello	a	b	
T 5000	70	35	
T 5010	80	35	
T 5020	85	35	
T 5030	90	45	
T 5040	105	45	
T 5050	106	55	
T 5060	112	50	
T 5070	123	55	
T 5090	136	53	

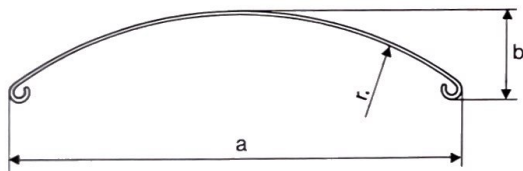

CROSS

ns. modello	a	b	r
T 5060 A	82	16	67
T 5060 B	92	22	64
T 5060 C	102	24	69
T 5060 D	114	34	67
T 3050 A	90	16	85
T 3050 B	100	19	90

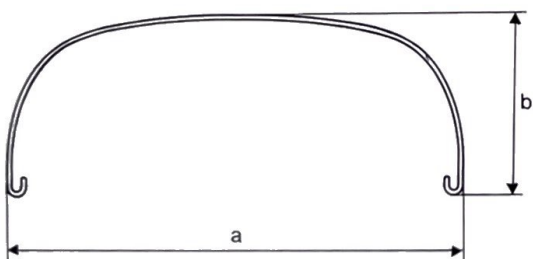

PIATTO

ns. modello	a	b	
P 3000	65	22	
P 3030	100	32	
P 3080	130	35	
P 3110	150	55	

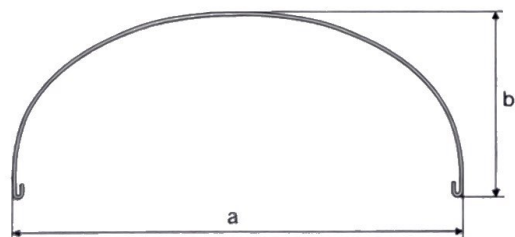

SEMITONDO

ns. modello	a	b	
P 3040	110	45	
P 3050	110	30	
P 3060	135	51	
P 3070	120	43	
P 3090	146	43	
P 3100	140	45	
P 3120	180	56	



parafanghi bastia s.r.l.

20136 MILANO (ITALY)
UFF. E STABILIMENTO
VIA C. BALBO, 4
TEL. (02) 545.26.98 - 593.107
FAX (02) 55.180.144
TELEX 310677/315648
ASLOMB I. 573 BASTIA

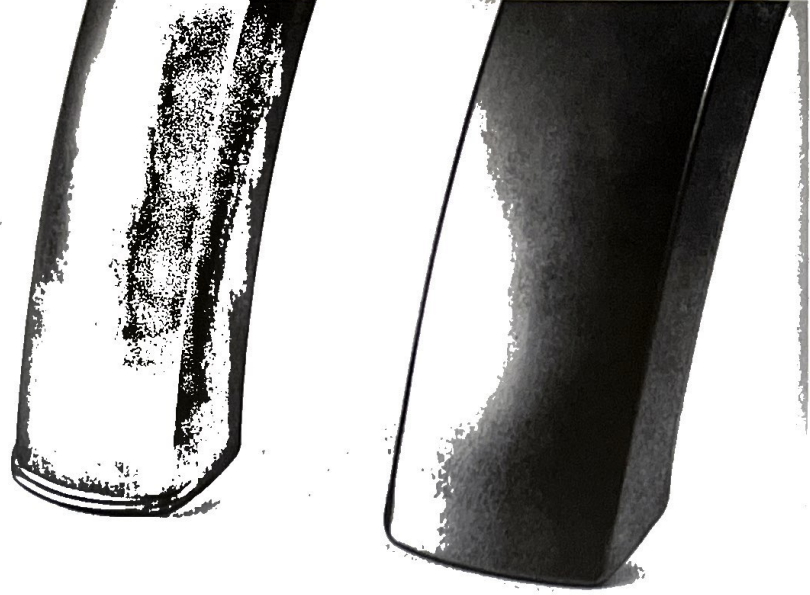

SAGOMATI

ns. codice	a	b	c	r/d	r/e	r/f	g
S 1000	82	42	60	95	55	—	—
S 9270	80	33	74	130	66	—	—
S 9290	78	36	59	49	59	—	—

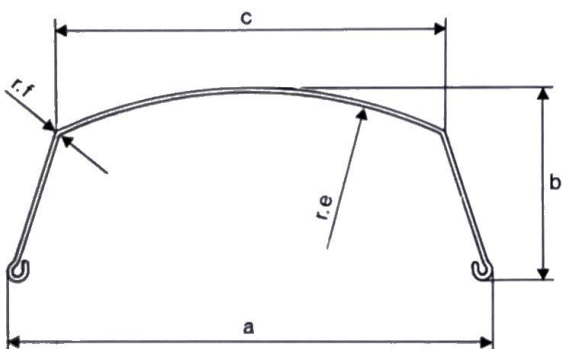
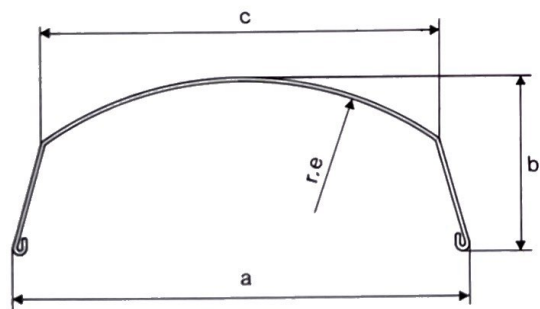
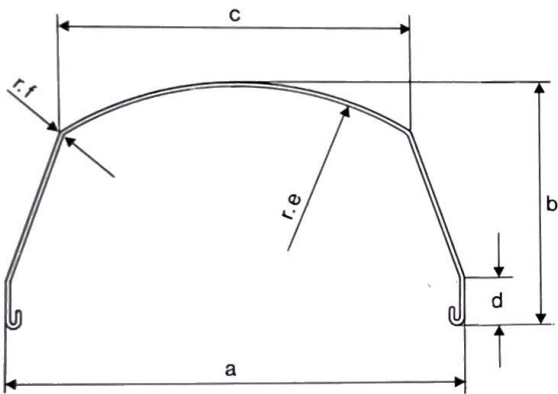
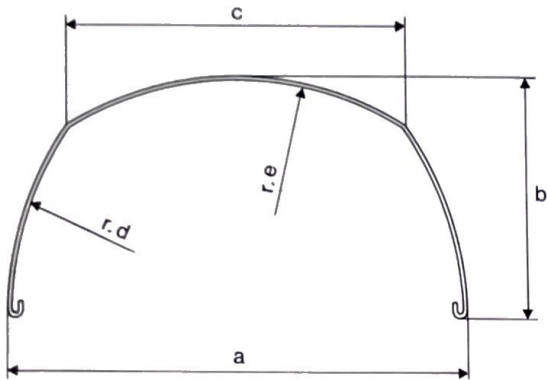

ns. codice	a	b	c	d	r/e	r/f	—
S 1000 A	80	42	60	—	55	—	—
S 9230 A	90	45	70	8	62	—	—
S 9320	135	50	112	10	210	6	—
S 9360	105	50	82	10	200	3	—
S 9360 A	100	35	82	8	200	3	—
S 9300	112	50	90	10	210	5	—

ns. codice	a	b	c	d	r/e	r/f	—
S 9040	76	29	62	—	70	—	—

ns. codice	a	b	c	d	r/e	r/f	—
S 9120	88	32	74	—	66	—	—
S 9120 A	80	20	74	—	66	—	—
S 9180	82	35	68	—	62	2	—
S 9230	92	45	70	—	62	—	—
S 9300 A	102	23	90	—	210	5	—



parafanghi bastia s.r.l.

20136 MILANO (ITALY)
UFF. E STABILIMENTO
VIA C. BALBO, 4
TEL. (02) 543.26.98 - 593.107
FAX (02) 54.189.144
TELEX 311677315648
ASLOMEN, 5/3 BASTIA

Via Papa XXIII
20080 Zibido Loc. S. Giacomo (MI)
Cod. Fisc. 05801240186

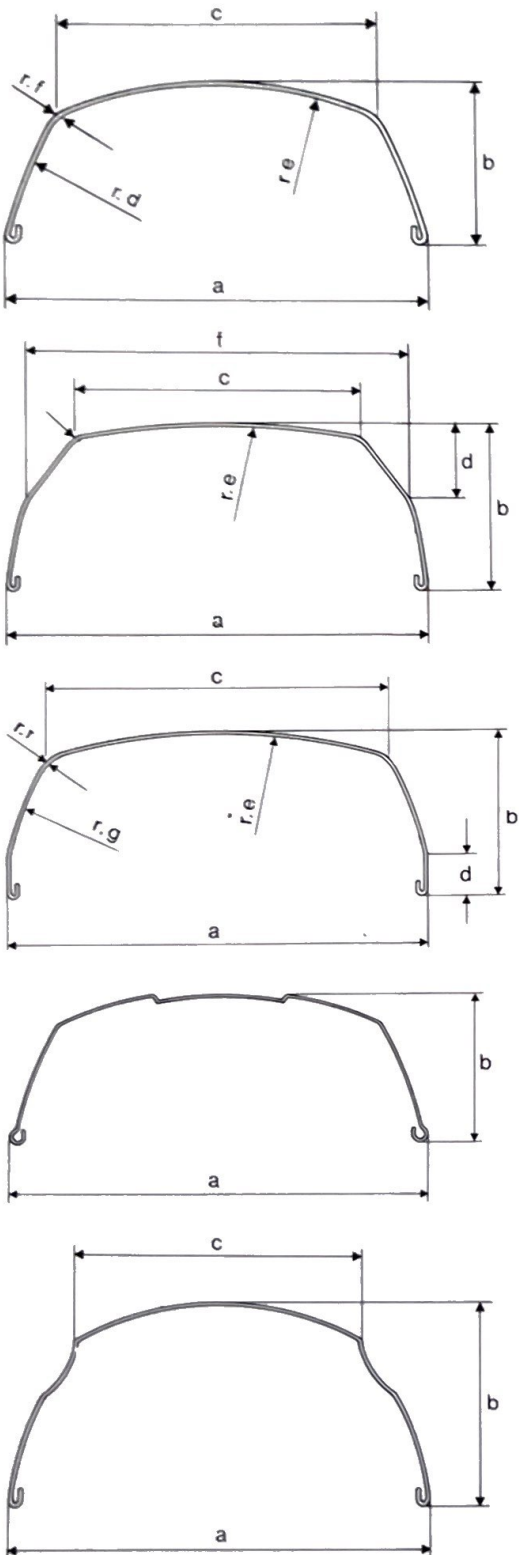

SAGOMATI (seguito)

ns. codice	a	b	c	r/d	r/e	r/f	—
S 9050	70	25	55	100	70	6	—
S 9060	76	35	56	120	75	5	—
S 9180 A	86	40	68	100	62	2	—
S 9270 A	86	37	74	70	66	2	—
S 9340	90	30	77	112	140	6	—
S 9380	80	40	65	95	90	9	—

ns. codice	a	b	c	d	r/e	f	—
S 9494	85	34	58	15	220	80	—

ns. codice	a	b	c	d	r/e	r/f	r/g
S 9340 A	95	36	77	8	140	6	120

ns. codice	a	b	—	—	—	—	—
S 9140	95	40	—	—	—	—	—
S 9150	110	45	—	—	—	—	—

ns. codice	a	b	c	—	—	—	—
S 9020	75	40	56	—	—	—	—



parafanghi bastia r.r.l.

20136 MILANO (ITALY)
UFF. E STABILIMENTO
VIA C. BALBO, 4
TEL. (02) 545.26.98 - 593.107
FAX (02) 55.180.144
TELEX 310677/315648
ASLOMB I. 573 BASTIA

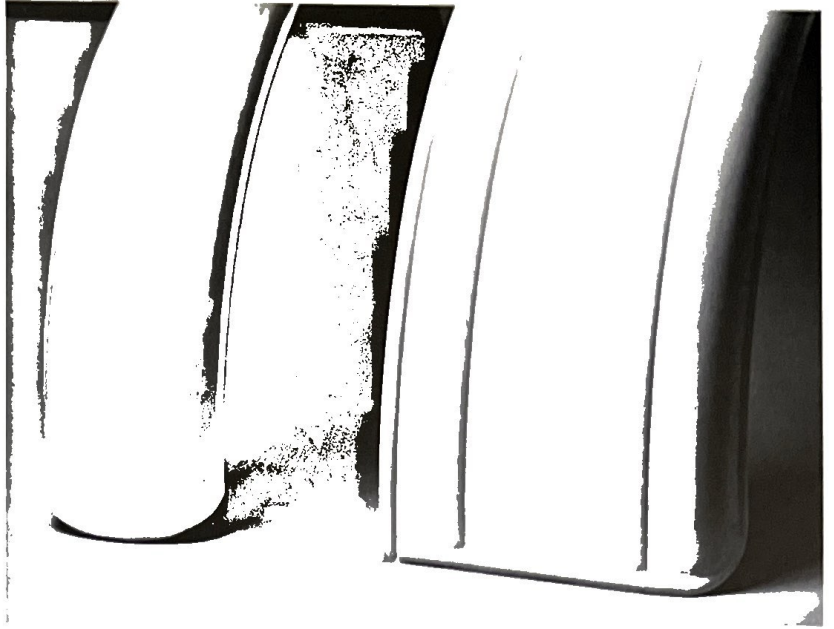

SAGOMATO G

ns. codice	a	b	r/c	r/d	r/e	r/f	—
S 9200 G	104	37	95	30	—	—	—
S 9260 G	95	30	75	28	—	—	—
S 9500 G	83	27	75	20	—	—	—

ns. codice	a	b	r/c	r/d	—	—	—
S 9210 G	112	50	103	20	—	—	—

ns. codice	a	b	c	r/d	r/e	r/f	—
S 9380 G	80	40	65	90	95	9	—
S 9280	92	50	76	50	300	—	—

SAGOMATI PER MOTOCARRI E AUTOCARRI LEGGERI

ns. codice	a	b	c	—	—	—	—
S 9160	170	70	92	—	—	—	—

ns. codice	a	b	c	—	—	—	—
S 9220	200	45	—	—	—	—	—
S 9230	220	45	—	—	—	—	—

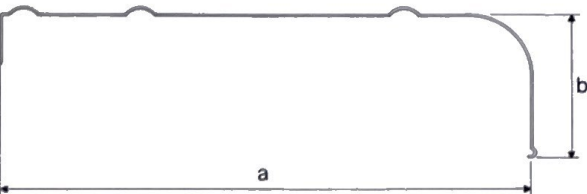
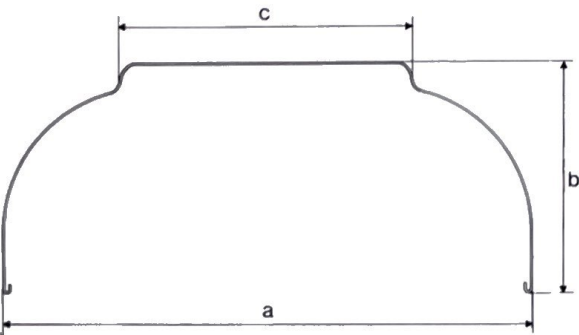
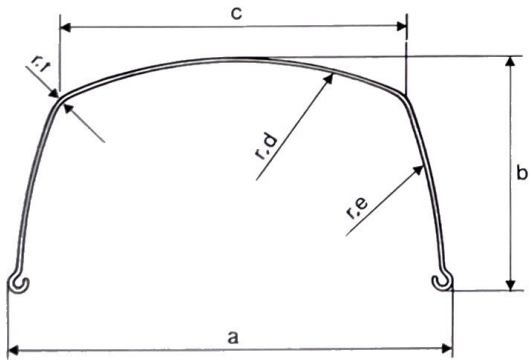
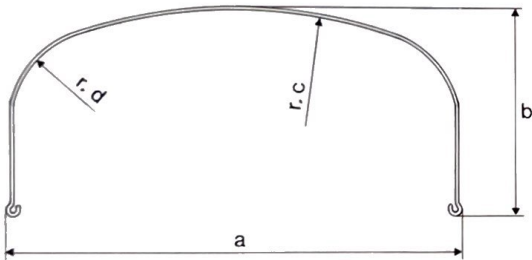
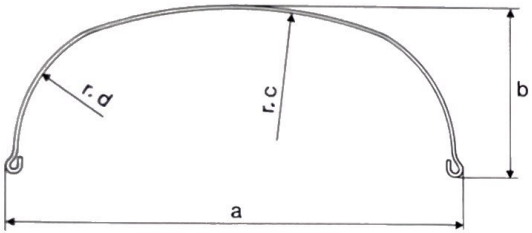



parafanghi bastia s.r.l.

Parafanghi Bastia S.r.l.
Via F.lli. Cervini XXIII
21080 Zabio Loc. S. Giacomo (MI)
Cod. Fisc. 0581240156

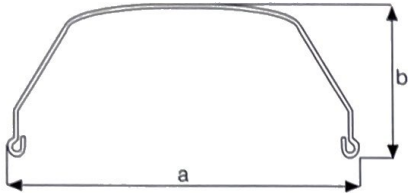

ns. codice	a	b	c	d	r.c	r.d	—
S 70 TR	70	30	—	—	—	—	—

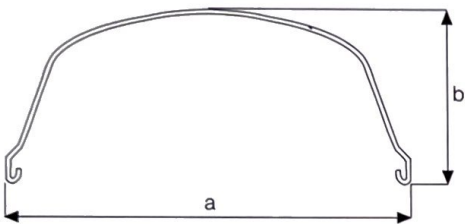

ns. codice	a	b	c	d	r.c	r.d	—
S 80 TR	80	35	—	—	—	—	—

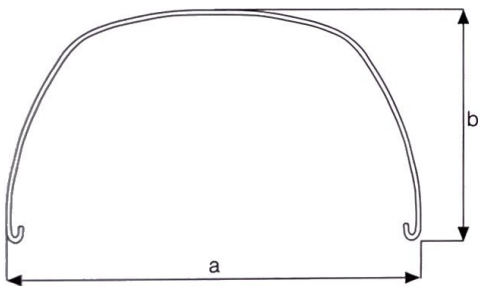

ns. codice	a	b	c	d	r.c	r.d	—
S 80/1 TR	80	47	—	—	—	—	—

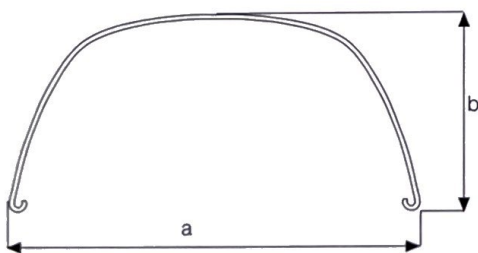

ns. codice	a	b	c	d	r.c	r.d	—
S 80/3 TR	80	40	—	—	—	—	—



parafanghi bastia s.r.l.

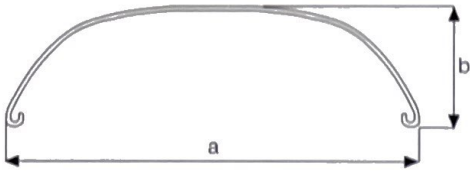

ns. codice	a	b	c	d	r.c	r.d	—
S 85 TR	85	23	—	—	—	—	—

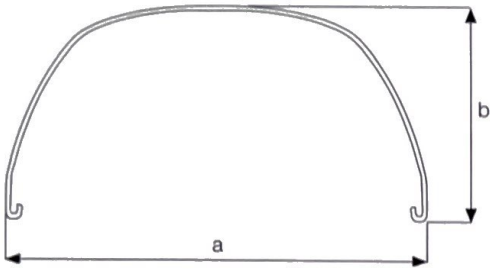

ns. codice	a	b	c	d	r.c	r.d	—
S 85/1 TR	85	45	—	—	—	—	—

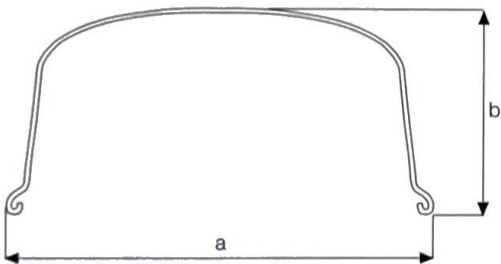

ns. codice	a	b	c	d	r.c	r.d	—
S 85/2 TR	85	42	—	—	—	—	—

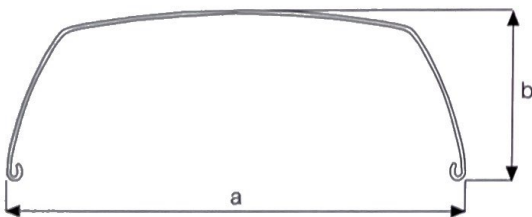

ns. codice	a	b	c	d	r.c	r.d	—
S 88 TR	88	34	—	—	—	—	—



parafanghi bastia s.r.l.

PARAFANGHI BASTIA S.r.l.
 Via Papa Giovanni XXIII
 20080 Zibido Loc. S. Giacomo (MI)
 Cod. Fisc. 05801240180

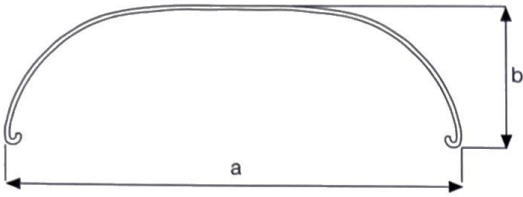

ns. codice	a	b	c	d	r.c	r.d	—
S 90 TR	90	30	—	—	—	—	—

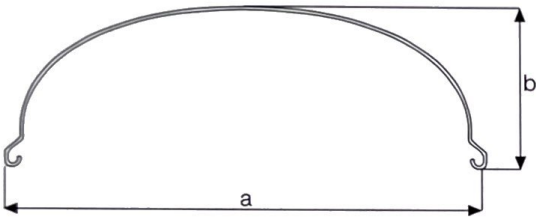

ns. codice	a	b	c	d	r.c	r.d	—
S 90/1 TR	90	30	—	—	—	—	—

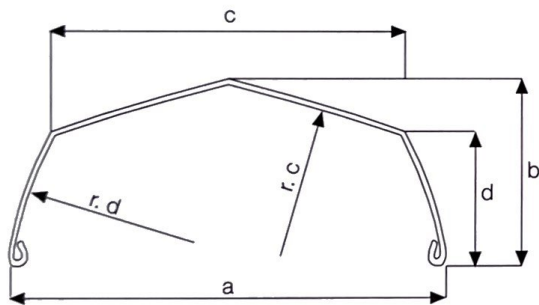

ns. codice	a	b	c	d	r.c	r.d	—
S 9400	82	35	64	25	500	70	—

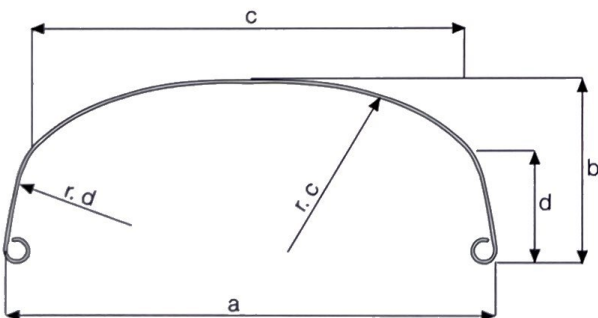

ns. codice	a	b	c	d	r.c	r.d	—
S 9420	90	34	83	19	71	80	—

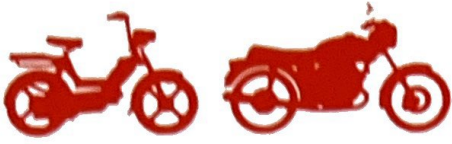

parafanghi bastia s.r.l.

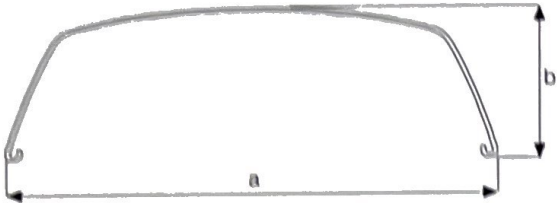

ns. codice	a	b	c	d	r.c	r.d	—
S 92 TR	92	30	—	—	—	—	—

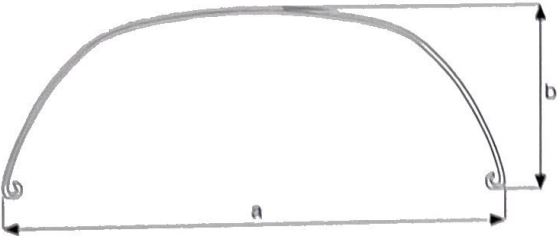

ns. codice	a	b	c	d	r.c	r.d	—
S 100 TR	100	38	—	—	—	—	—

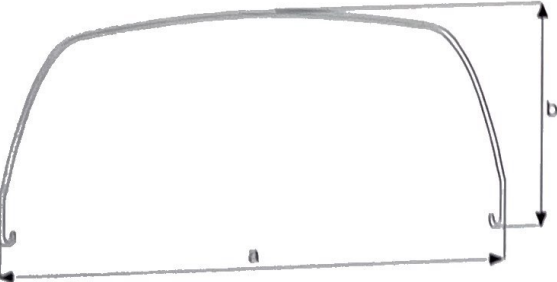

ns. codice	a	b	c	d	r.c	r.d	—
S 100/1 TR	100	45	—	—	—	—	—

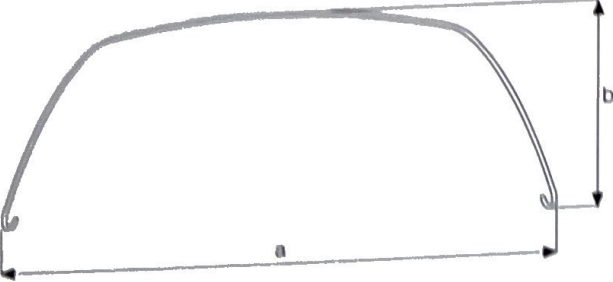

ns. codice	a	b	c	d	r.c	r.d	—
S 110/1 TR	110	43	—	—	—	—	—



produzione PEUGEOT

modello per ciclomotore

SP 103

anteriore/avant/front/hinter

cod.



posteriore/arriere/rear/vorder

cod.

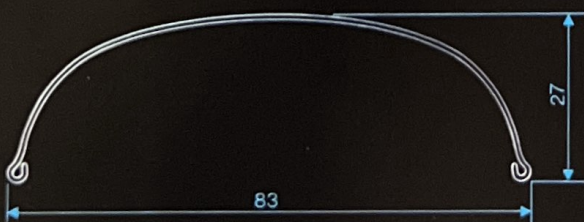

profilo anteriore mod. S 9500 G

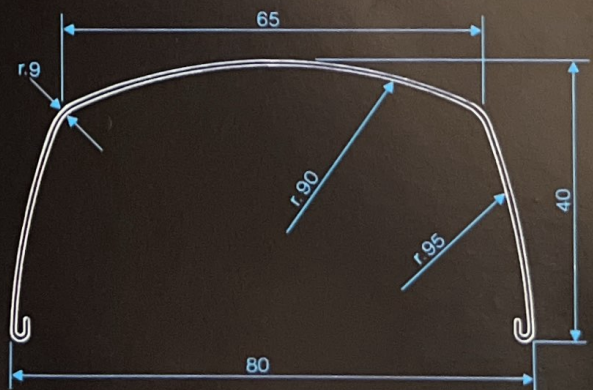

profilo posteriore mod. S 9380



produzione PEUGEOT

modello per ciclomotore

MVL 103

anteriore/avant/front/hinter

cod.



posteriore/arriere/rear/vorder

cod.



profilo

mod. S 9380

